

X2 Synergy

MA X2 Moisture Analyzer

USER MANUAL

IMMU-21-05-01-17-EN



www.radwag.com

If you are reading this, it means that you are bound to achieve success. You have purchased a device that has been designed and manufactured to give you years of service. Congratulations and thank you for selecting RADWAG product.

JANUARY 2017

Contents

| | |
|--|-----------|
| 1. GENERAL INFORMATION..... | 6 |
| 2. GENERAL SAFETY PRECAUTIONS | 7 |
| 2.1. Warning Symbols and Signals | 7 |
| 2.1.1. Warning Descriptions..... | 7 |
| 2.1.2. Warning Symbols | 7 |
| 2.2. Precautions | 7 |
| 2.3. Intended Use | 8 |
| 2.4. Warranty Conditions | 9 |
| 2.5. Precautions | 9 |
| 2.6. Warranty..... | 10 |
| 2.7. Supervision over Metrological Parameters | 10 |
| 2.8. User Manual Significance..... | 10 |
| 2.9. Staff Competence..... | 10 |
| 2.10. Protective Clothing | 10 |
| 3. TRANSPORT AND STORAGE..... | 11 |
| 3.1. Delivery Checklist..... | 11 |
| 3.2. Package | 11 |
| 4. UNPACKING AND INSTALLATION..... | 11 |
| 4.1. Place of Use and Assembling..... | 11 |
| 4.2. Unpacking | 12 |
| 4.3. Balance Level Setting..... | 12 |
| 4.4. Standard Delivery Components List | 12 |
| 4.5. Maintenance Activities | 13 |
| 4.6. Powering the Device | 14 |
| 4.7. Temperature Stabilisation Time..... | 14 |
| 4.8. Connecting Additional Hardware..... | 14 |
| 5. START-UP | 15 |
| 6. KEYBOARD – BUTTONS FUNCTIONS..... | 15 |
| 7. WEIGHING MODE HOME SCREEN | 16 |
| 7.1. Weighing Window..... | 16 |
| 7.2. Drying Window | 17 |
| 8. ENTERING BALANCE MENU | 18 |
| 8.1. Entering Balance Menu..... | 18 |
| 8.2. Screen Scrolling | 18 |
| 8.3. Soft Keys List | 19 |
| 8.4. Running Software Functions | 19 |
| 8.5. Return to Weighing Mode | 20 |
| 8.6. Buttons, Labels and Text Fields Configuration | 21 |
| 8.6.1. Quick Access Keys | 23 |
| 8.6.2. Labels | 25 |
| 8.6.3. Text Fields | 27 |
| 8.6.4. Bargraphs | 28 |
| 9. WEIGHING OPERATION | 30 |
| 9.1. Good Weighing Practice..... | 30 |

| | |
|--|-----------|
| 9.2. Logging..... | 30 |
| 9.3. Units..... | 31 |
| 9.4. Weighing Unit Selection | 31 |
| 9.5. Weighing Units Accessibility..... | 32 |
| 9.6. Start Unit Selection | 32 |
| 9.7. User-defined Unit | 33 |
| 9.8. Balance Zeroing | 33 |
| 9.9. Balance Taring | 33 |
| 9.10. Weighing Mode Settings..... | 35 |
| 9.11. Proximity Sensors | 36 |
| 9.12. AUTOTARE | 36 |
| 9.13. Print Mode..... | 37 |
| 9.14. Minimum Sample Weight..... | 38 |
| 9.15. Cooperation with TITRATORS..... | 40 |
| 10. MISCELLANEOUS..... | 41 |
| 11. ADJUSTMENT | 43 |
| 11.1. External Adjustment | 43 |
| 11.2. User Adjustment | 44 |
| 11.3. Report Printout | 44 |
| 11.4. Temperature Adjustment..... | 44 |
| 11.5. Drying Process Test | 46 |
| 12. DETERMINING PRINTOUT CONTENT | 48 |
| 12.1. Adjustment Report | 48 |
| 12.2. Drying Process Report Printout..... | 49 |
| 12.3. Other Printouts | 51 |
| 12.4. Non-standard Printouts | 53 |
| 12.4.1. Inserting Texts | 53 |
| 12.5. Variables | 56 |
| 13. WORKING MODES – GENERAL INFORMATION..... | 57 |
| 13.1. Working Modes Accessibility | 57 |
| 13.2. Running Working Mode | 57 |
| 13.3. Parameters Related to a Working Mode | 58 |
| 14. DATABASES..... | 58 |
| 14.1. Database Connected Operations..... | 58 |
| 14.2. Products..... | 60 |
| 14.3. Users | 60 |
| 14.4. Packaging..... | 60 |
| 14.5. Customers..... | 60 |
| 14.6. Drying Program..... | 61 |
| 14.7. Drying Process Reports | 61 |
| 14.8. Ambient Conditions | 61 |
| 14.9. Weighing Records..... | 62 |
| 15. SAMPLE PREPARATION FOR DRYING | 63 |
| 15.1. Means of Moisture Content Measurement on a Moisture Analyzer | 63 |
| 15.2. Sampling and Preparation | 63 |
| 16. SELECTION OF DRYING PARAMETERS..... | 65 |

| | |
|--|------------|
| 16.1. Selecting Optimum Mass for a Sample | 65 |
| 16.2. Influence of Sample Weight on Measurement Result Repeatability | 66 |
| 16.3. Drying Temperature | 66 |
| 16.4. Selecting Drying Profile | 66 |
| 16.5. Drying Time..... | 67 |
| 16.6. Drying Profile Analysis | 68 |
| 17. DRYING PROCESS PERFORMED BY MEANS OF QUICK MENU | 68 |
| 17.1. Drying Process Profile and Drying Parameters | 69 |
| 17.2. Automatic Finish Mode | 70 |
| 17.3. Unit of Displayed and Printed Measurement | 70 |
| 17.4. Printout interval | 71 |
| 18. DRYING PROCESS PERFORMED WITH USE OF DRYING MODES | |
| DATABASE | 71 |
| 19. DRYING PROCESS | 72 |
| 20. COMMUNICATION | 76 |
| 20.1. RS 232 Ports Settings | 76 |
| 20.2. ETHERNET Port Settings..... | 76 |
| 20.3. Wi-Fi Port Settings | 76 |
| 20.4. USB Ports..... | 79 |
| 21. PERIPHERALS | 83 |
| 21.1. Computer | 83 |
| 21.2. Printer | 85 |
| 21.3. USB Flash Drive | 88 |
| 21.4. Barcode Reader..... | 88 |
| 21.5. Ambient Conditions Module | 89 |
| 22. AMBIENT CONDITIONS | 89 |
| 23. COMMUNICATION PROTOCOL | 91 |
| 23.1. List of Commands..... | 91 |
| 23.2. Response Format | 92 |
| 23.3. Manual Printout / Automatic Printout | 103 |
| 24. PERIPHERALS | 103 |
| 25. ERROR MESSAGES..... | 104 |
| 26. USE OF MOISTURE ANALYZER..... | 104 |
| 27. MAINTENANCE ACTIVITIES | 105 |
| 27.1. Cleaning Moisture Analyzer Components | 105 |
| 27.2. Cleaning Temperature Sensor | 106 |
| 27.3. Troubleshooting | 106 |
| 28. ADDITIONAL EQUIPMENT | 107 |
| 29. INFORMATION ON MOISTURE ANALYZER | 107 |

1. GENERAL INFORMATION

Dimensions:

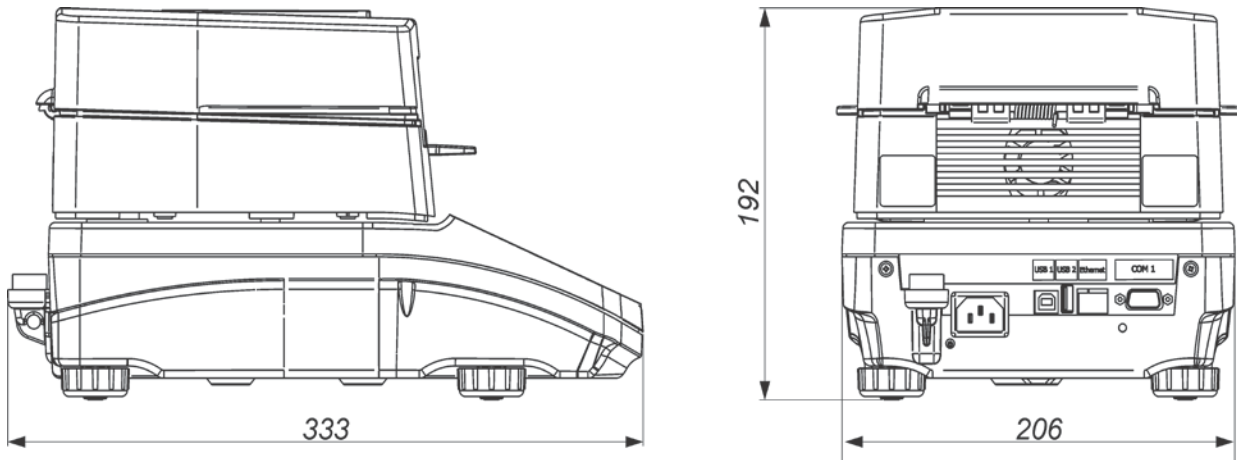

Connectors:

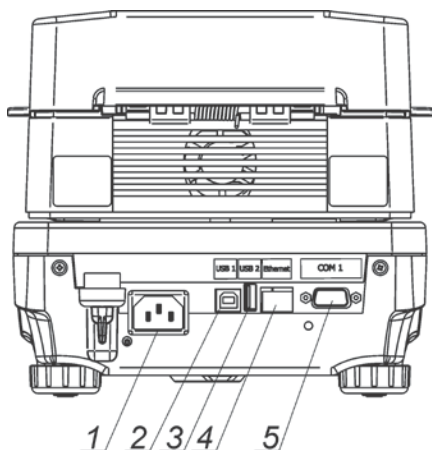

1. Power supplier connector
2. USB 2 type B connector
3. USB 1 type A connector
4. ETHERNET connector
5. COM connector

Diagrams of connection cables:

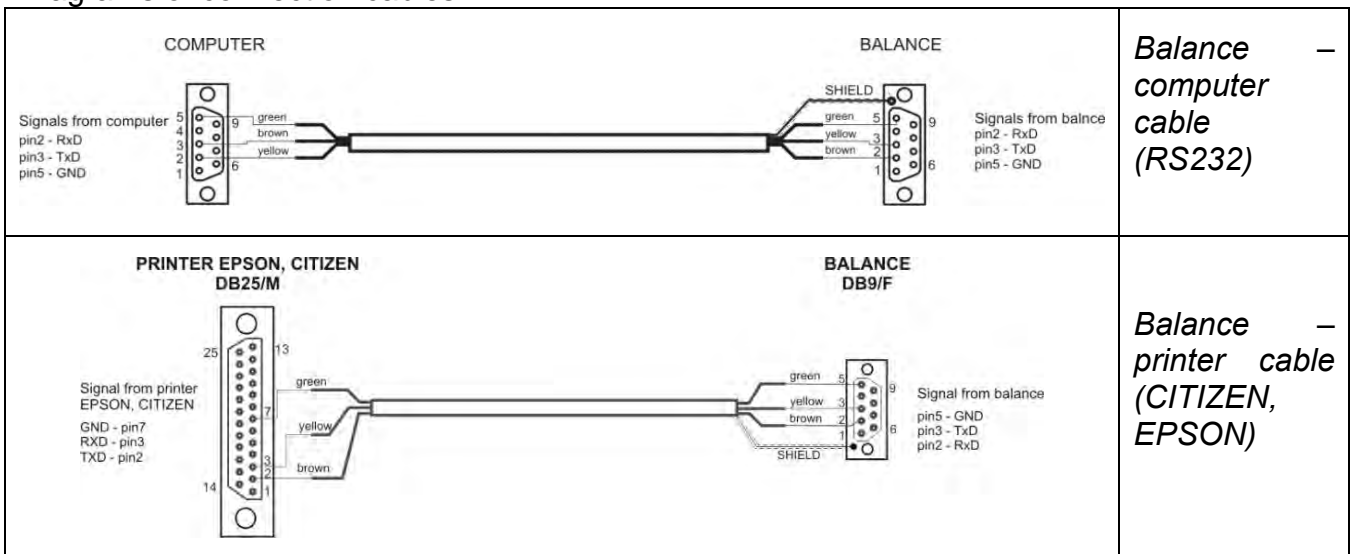

2. GENERAL SAFETY PRECAUTIONS

2.1. Warning Symbols and Signals

Safety precautions are marked with special descriptions and warning signs. They inform and warn a user of possible dangers. Ignoring the safety warnings may cause injuries, damage of the moisture analyzer, its inappropriate operation and errors of measurements.

2.1.1. Warning Descriptions

- WARNING** Medium risk danger that can lead to a serious injury or death.
- CAUTION** Low risk danger that can lead to moisture analyzer damage or dysfunction, loss of data or minor or moderate injury.
- NOTE** Critical information on the moisture analyzer.

2.1.2. Warning Symbols



Electric shock



Acid / Corrosion



Potential danger



Flammable or explosive substances



Toxic substances



Hot surface

2.2. Precautions

WARNING!

Adherence to safety information and user manual guidelines is required in order to prevent risk of health damage and even death.



WARNING:

Nominal voltage for a moisture analyzer is 230V AC. It means that safety usage precautions for low voltage devices must be abided by while operating the device. The moisture analyzer is equipped with a three-core power supply cable with grounding pin. If necessary, an extension cord can be used provided that it meets the applicable standards and has a protective ground conductor. Intended disconnection of the grounding cable is forbidden.



CAUTION:

Drying chamber cannot be opened during operation (drying process). It is due to the fact that a halogen lamp and its glass shield may reach the temperature of up to 400° C. When setting up the moisture analyzer leave enough space to prevent heat from building up and to keep your analyser from overheating. Leave about 20 cm around the instrument and about 1 m above. Air vents that are located in the housing cannot be covered, sealed or blocked in any other way. Do not put any flammable substances on, under or near the moisture analyzer. Be particularly careful when removing the sample from the drying chamber: the sample itself, the drying chamber, shields and the pan can still be extremely hot. In case of any maintenance work (cleaning the inside of the drying chamber), the moisture analyzer must be switched off. Wait until all the components have cooled down. Do not perform any modification to the heating module.

Some types of samples require taking particular safety precautions.

They can pose a danger for people and objects. It is always the user who is liable for possible damages caused by the use of an inappropriate sample.



CAUTION:

Corrosion: substances that release aggressive vapours (e.g. acids) during the heating process. While drying such substances it is recommended to work with small samples. Otherwise, vapours can condense on cold housing parts and cause corrosion.



WARNING:

Fire or explosion: flammable or explosive substances, substances containing solvents or releasing flammable or explosive gases or vapours. When in doubt as for the sample's characteristics perform risk analysis before carrying out the procedure. For the said type of samples, apply as low drying temperatures as possible, thus preventing flames or explosion. During the analysis it is necessary to wear protective glasses and gloves. The samples should be relatively small. **Under no circumstances can the instrument be left unsupervised!**



WARNING:

Substances containing toxic and caustic or corrosive components: substances that release toxic gases or vapours can cause irritations (eyes, skin or respiratory system), illnesses or even death. Dry such substances only in fume cupboards.

Under no circumstances should the instrument be used within an explosion endangered area. The moisture analyzer is designed to be operated outside hazardous areas exclusively.

2.3. Intended Use

Moisture analyzer is designed to verify relative moisture content in small samples of various substances, dry mass content in small samples and mass of weighed objects. The device ensures fast and precise process of determination of water content in a tested sample whereas application of touch screen display considerably simplifies operation and improves functionality of the moisture analyzer. The device can be used to determine humidity content of different materials.

At the initial stage of the measurement, the moisture analyzer precisely determines mass of an object placed on a weighing pan. As the mass reading is stabilized, the sample is quickly

heated by a halogen lamp, an IR emitter or a metal heater causing humidity evaporation from the tested sample. While sampling, the moisture analyzer is continuously checking loss of mass, and on calculation, it displays current moisture content of a tested sample. Compared to conventional methods of humidity content determination of various substances, application of moisture analyser considerably shortens measurement time and simplifies testing procedure. Moisture analyzer facilitates setting multiple parameters which influence the procedure of moisture content determination in a sample (temperature, time, drying modes, etc.).

2.4. Warranty Conditions

CAUTION!

Do not open the drying chamber during the drying process. The moisture analyzer features a halogen lamp which is a very powerful heat source. Pay special attention not to touch those elements of a moisture analyzer that get hot while the drying procedure (i.e.: disposable pan, pan handle, and inner shields of the drying chamber).

Remember that some tested samples may become dangerous when heated (emission of poisoning vapours, danger of ignition or explosion).

The moisture analyzer is not intended for dynamic weighing. Even if small amounts of a sample are added to or taken off the weighing pan, the mass readout should be taken only on stabilization of the measurement result (appearance of stability pictogram  on the display).

Do not place any magnetic materials on the weighing pan, as this can cause damage of the measuring system of the instrument.

Be sure to avoid impact shock and overloading of the moisture analyzer in excess of the prescribed maximum measuring range (max capacity), minus any possible tare weight that has been applied).

Never use the moisture analyzer in an environment endangered by an explosion!

This moisture analyzer is not adjusted for operation in explosive areas. Remember that it is forbidden to make any modification to the moisture analyzer.

2.5. Precautions

RADWAG moisture analyzer adheres to all binding safety regulations. Nevertheless there are exceptional circumstances that may cause danger.

Do not open the instrument's housing. Inside there are no parts that would require maintenance, repair or replacement carried out by a user. In case of any problems, contact RADWAG service or a distributor.

Remember to use the device in accordance with this user manual, especially to follow instructions on installation and configuration of a new device.

Since use of the moisture analyzer conversely to safety precautions and user manual guidelines may be hazardous to operator's health and life, it is obligatory to read them carefully:

- Use the moisture analyzer to determine humidity content in samples and to determine mass of a tested sample; any other use of the moisture analyzer may be dangerous both to the device and the user,
- Before commissioning the moisture analyzer, make sure that the nominal power of the device specified on its data plate is compatible with the supply in the mains to which the moisture analyzer is to be plugged in,
- **Halogen lamps can only be changed by an authorized service employee,**
- Protect moisture analyzer against contacts with liquids, it might lead to electrocution, fire, emission of substances containing toxic or caustic vapour, emission of explosive substances.

2.6. Warranty

Warranty does not cover the following cases:

- not observing the user manual regulations,
- using the moisture analyzer conversely to its intended use,
- any modifications of a moisture analyzer or cases when its housing has been opened (damaged protective stickers),
- mechanical defects and defects caused by media, liquids, water and natural wearing off,
- inappropriate working environment or electrical installations defects,
- overloading of measuring mechanism.

2.7. Supervision over Metrological Parameters

Metrological parameters of a moisture analyzer need to be checked by a user in determined time intervals. Inspection frequency is conditioned by ambient conditions in which a moisture analyzer is used, kind of carried out processes and adopted quality management system.

2.8. User Manual Significance

It is very important to read the user manual carefully before switching on and starting up moisture analyzer operation, even if you are experienced and have worked with this type of balance before.

2.9. Staff Competence

The moisture analyzer should be utilized and supervised only by users who are trained and experienced in such type of instruments.

In order to use the moisture analyzer, first read the user manual. Keep these instructions for the future reference.

Do not make any design modifications. Additional equipment compatible with the moisture analyzer and spare parts should be supplied by RADWAG or an authorized distributor.

2.10. Protective Clothing

While working with the instrument use protective clothing, this is to take safety precautions against potential hazards source of which might be tested samples and ingredients.

Use the following while carrying out tests:

- protective apron,
- protective glasses,
- protective gloves (while working with hazardous chemical substances).

Before the use of the above-mentioned protective clothing, make sure that it has been designed to be used with specific samples and that it is not damaged.

3. TRANSPORT AND STORAGE

3.1. Delivery Checklist

Upon delivery it is necessary to check the package, make sure that your package bears no signs of damage.

3.2. Package

Keep all package elements should your device be transported in the future. Remember that only original packaging can be used for shipping purposes. Prior packing uncouple any cables, remove any separable components (weighing pan, shields, inserts). The device components shall be packed into an original packaging, thus being protected against potential damage during transportation.

4. UNPACKING AND INSTALLATION

4.1. Place of Use and Assembling

- Store and use your moisture analyzer in locations free of vibrations and shakes, and free of air movement and dust, make sure that it is located at the max altitude of 2000 above sea level.
- Make sure that the moisture analyzer's workplace ensures good air circulation around the instrument (approximately 20 cm free space around the moisture analyzer and 1 m free space over it).
- Pay attention to the ambient air temperature in the weighing room, it should not be out of the specified range, i.e. +10 °C - +40 °C.
- Pay attention to the ambient relative humidity, for temperature ranging up to 31°C it should be 80% maximum, and it should decrease linearly to 50 % for temperature of 40°C.
- Make sure that the moisture analyzer is placed away from heat sources on a stable wall console desk or on a stable table which is not affected by vibrations.
- Since part of the balance is a strong magnet take special safety measures when weighing magnetic objects.

4.2. Unpacking

Carefully take the device out of the packaging, remove the transport lock and gently place the moisture analyzer at its workplace. Install the weighing pan and accessories following the diagram below:

Accessories installation:

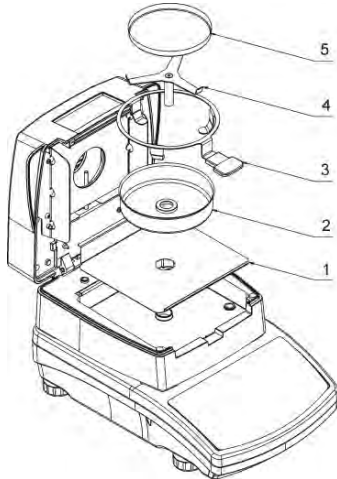

Install:

- Drying chamber base insert (1),
- Anti-draft chamber (2),
- Pan handle (3),
- Cross-shaped holder (4),
- Disposable pan (5).

Positioning the bracket:

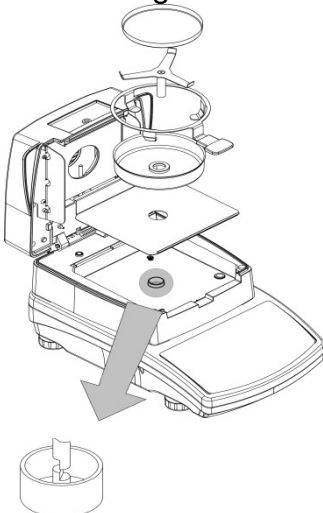

When installing the cross-shaped holder (pan supporter) pay special attention to the correct positioning of its mandrel. The mandrel features a cut providing unique positioning of the holder against the pan handle, thus preventing their contact and friction.

Setting the cross-shaped holder:

- assemble the holder onto the mandrel and turn it slightly so that the mandrel cuts are located in their unique and correct position,
- **CAUTION:** *turn the mandrel gently so as not to damage moisture analyzer's measuring system.*

4.3. Balance Level Setting



It is necessary to level the balance prior connecting it to the mains. To level the balance turn its feet until an air bubble takes central position.

4.4. Standard Delivery Components List

- Moisture analyzer,
- Drying chamber base insert,
- Drying pan shield,
- Drying pan handle,
- Cross-shaped holder,
- Disposable pan,
- Power cord,
- User manual – CD version.

4.5. Maintenance Activities

1. Disassembly a weighing pan and other detachable components (the components differ depending on a balance type – see *Unpacking and Installation* section). Be careful while detaching the components so as not to cause any damages to the balance mechanism.
2. In order to ease cleaning of glass anti-draft chamber panes, it is permissible to remove them following the below instruction.

CAUTION! Cleaning anti-draft chamber while still installed may cause damage of the measuring system.

Cleaning ABS components:

To clean dry surfaces and avoid smutching use clean non-colouring cloths made of cellulose or cotton. You can use a solution of water and detergent (soap, dishwashing detergent, glass cleaner). Gently rub the cleaned surface and let it dry. Repeat cleaning process if needed.

In the case when contamination is hard to remove, e.g. adhesive, rubber, resin, polyurethane foam residues etc., you can use a special cleaning agents based on a mixture of aliphatic hydrocarbons that do not dissolve plastics. Before using the cleanser for all surfaces we recommend carrying out tests. Do not use products containing abrasive substances.

Cleaning anti-draft chamber panes:

Select dissolvent depending on a dirt. Never soak the glass panes in alkaline solutions since they interact with glass and may cause damage. Do not use abrasive substances.

For organic dirt use acetone first, next use water or detergent. For other than organic dirt use diluted acid solutions (soluble salts of hydrochloric or nitric acid) or base solutions (ammonium or sodium base).

To remove ACIDS use protofilic solvent (sodium carbonate), to remove BASE use protogenic solvent (mineral acid of various concentration).

In case of heavy contamination use brush or detergent nevertheless avoid detergents containing large and hard molecules which could potentially scratch glass panes.

Use soft brush with wooden or plastic handle exclusively to avoid risk of scratches. Do not use wire brush.

At the end of the cleaning process rinse the pane using running water first, distilled next.

Rinsing is a necessary cleaning process stage allowing to remove remaining soap, detergents and other cleansers from the panes prior their reinstallation.

Avoid drying the panes either using paper towel or forced air circulation since some fibres, grains or contamination of other type could permeate into the panes thus causing weighing errors.

One shall not use driers when drying measuring glass tools.

It is a frequent treatment to leave glass components on a rack to dry.

Cleaning stainless steel components:

Avoid using cleansers containing any corrosive chemicals, e.g. bleach (containing chlorine). Do not use abrasive substances. Always remove the dirt using microfiber cloth to avoid damage of protective coating.

In case of a daily maintenance:

- 1. Remove the dirt using cloth dipped in warm water.*
- 2. For best results, add a little dishwashing detergent.*

Cleaning powder-coated components:

For preliminary cleaning stage you need running water or wet sponge featuring large holes, this will help you to remove loose, heavy dirt.

Do not use cleansers containing abrasive substances.

Next using cloth and cleanser-water solution (soap, dishwashing liquid) gently rub the cleaned surface.

Avoid using cleanser without water since it may result with damage of the cleaned surface, please mind that large amount of water mixed with cleanser is a must.

Cleaning aluminium components:

While cleaning aluminium components use products acid by nature, e.g. spirit vinegar, lemon. Do not use abrasive substances. Avoid using hard brush, this may cause scratches. It is recommended to use microfiber cloth.

While polishing the surface use circular movements. Use clean, dry cloth.

4.6. Powering the Device

A moisture analyzer can be plugged to the mains only by means of an original power cord, which comes standard with the moisture analyzer. Rated voltage (specified on the device's data plate) must be compatible with the mains rated voltage.

The power cord can be connected only to a socket with a ground contact. Plug the power cord to the moisture analyzer. The moisture analyzer's power plug is located at the back of its housing.

Moisture analyzer display shows name and program number first, next an indication 0.000 g (balances with readability of 1 mg) or 0.0000 g (balances with readability of 0,1 mg). If the indication does not equal zero, press **→0←** button.

4.7. Temperature Stabilisation Time

Before start of measuring processes, it is necessary to wait until the moisture analyzer reaches thermal stabilisation.

For moisture analyzers that were stored in much lower temperatures before plugging to mains (e.g. during winter period), thermal stabilisation period shall take at least 4 hours. During the thermal stabilization, the indications on a display panel can change. It is recommended that ambient temperature changes at place of use were insignificant (slow to change).

4.8. Connecting Additional Hardware









Use only accessories and peripheral equipment recommended by the manufacturer. The moisture analyzer must be disconnected from the mains before connecting or disconnecting any peripherals (printer, PC computer, USB type computer keyboard or additional display). On connecting the peripherals, plug the balance to the mains.

5. START-UP

- Plug the power adapter to a socket, next connect the connector to port located at the back of the housing.
- Press  button located in the top right hand corner of the terminal.
- Wait until start-up procedure is completed, the home screen of balance software is displayed automatically.
- The balance runs with no user logged in. In order to start operation it is necessary to carry out the logging procedure (for detailed logging procedure read later sections of this user manual).

6. KEYBOARD – BUTTONS FUNCTIONS



| Button | Overview |
|---|--|
|  | Press to switch the balance ON/OFF |
|  | Press to Zero the balance |
|  | Press to Tare the balance |
|  | Press to send measurement to a printer or a computer |
|  | Function key <Esc>, press to abandon parameter changes or exit to previous menu level |
|  | Function key <Home>, press to exit to home screen |
|  | Programmable proximity sensors, press to enable operation of freely selected functions |
|  | |

7. WEIGHING MODE HOME SCREEN

7.1. Weighing Window

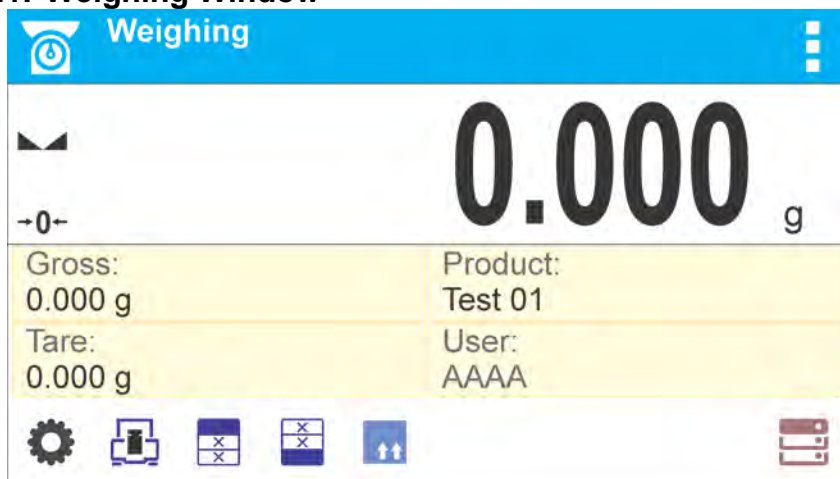

The main window of balance software can be divided into 3 sections:

- Top section displaying data on active working mode (pictogram and name), metrologically important data and button enabling selection of functions available for a particular working mode:



- Section presenting the weighing result:



- Section comprising supplementary information on currently performed operations, and function buttons:

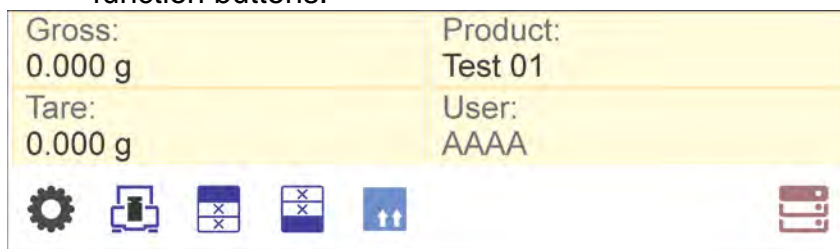

CAUTION!

Data and buttons contained in the workspace are freely configurable. For detailed information on data and buttons configuration refer to section 8 of this user manual.

7.2. Drying Window

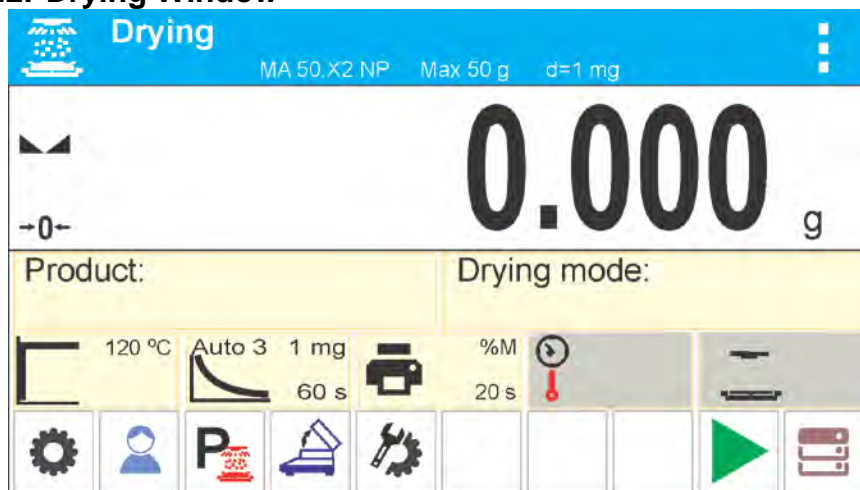

The main window of balance software can be divided into 3 sections:

- Top section displaying data on active working mode (pictogram and name), metrologically important data and button enabling selection of functions available for a particular working mode:

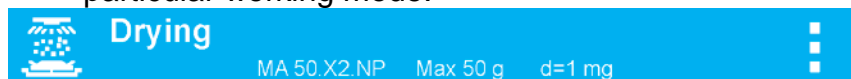

- Section presenting the weighing result:

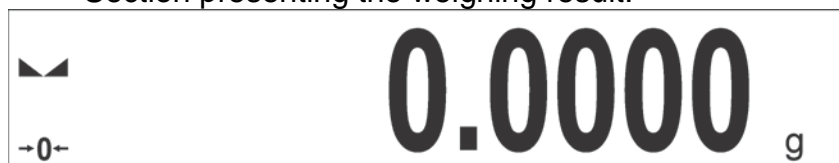

- Section comprising supplementary information on currently performed operations, and function buttons:



CAUTION!

Data and buttons contained in the workspace are freely configurable. For detailed information on data and buttons configuration refer to section 8 of this user manual.

8. ENTERING BALANCE MENU

Operation of balance software menu is intuitive and uncomplicated. The touch panel makes the software operation easy. Pressing a function key, a soft key or an area on the display initiates an assigned function or process.

8.1. Entering Balance Menu

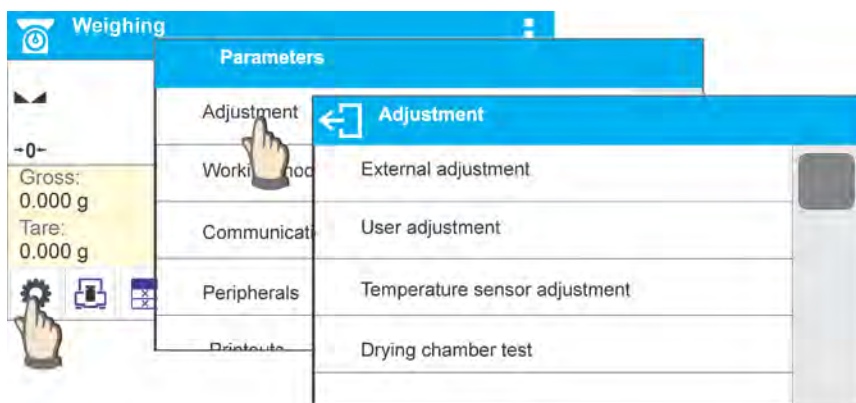





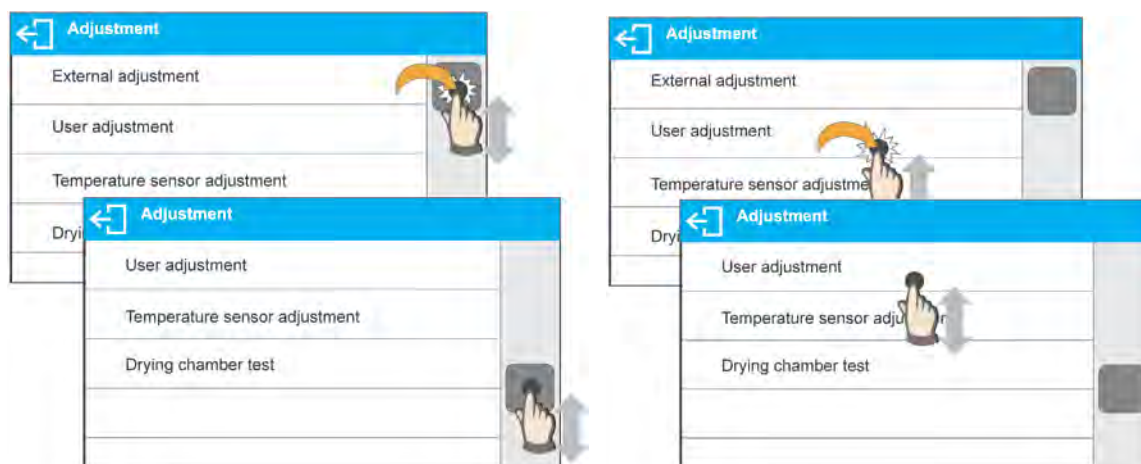







In order to enter balance menu, press  <PARAMETERS> button. Clicking any button comprised within information section, or clicking any button with particular parameter name, results with change of colour. This is for signalling purposes. If a given area has any function or action assigned, then it is performed automatically upon clicking (e.g. adjustment procedure), respectively a particular window with parameters or list of appropriate settings is displayed.

8.2. Screen Scrolling



There are two methods for scrolling the screen of parameters window. The first one requires pressing, holding down and scrolling up or down the scrollbar located on the left. The second one requires pressing, holding down and scrolling up or down any point of the displayed window.

8.3. Soft Keys List

| | | | |
|---|--|---|---|
|  | Press to enter the main menu. |  | Press to clear the editing field. |
|  | Press to scroll the menu „up”, or „down”. |  | Press to enable / disable an on-screen keyboard. |
|  | Press to confirm changes. |  | Press to export databases (key active upon plugging a pen drive). |
|  | Press to resign form introducing function modifications. |  | Press to import databases (key active upon plugging a pen drive). |
|  | Press to add a new record to a database. |  | Press to select variables, out of the list, for a printout. |
|  | Press to print out a particular record from a database. |  | Press to delete database's content |

8.4. Running Software Functions

- Quick access key

| | |
|---|---|
|  | <p>Press to enter parameters setup.</p> |
|---|---|

- Label:

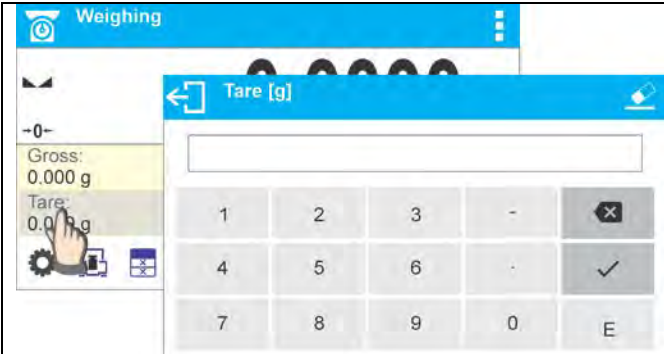
| | |
|---|-----------------------------------|
|  | <p>Press to enter tare value.</p> |
|---|-----------------------------------|

- Text field with function assigned:

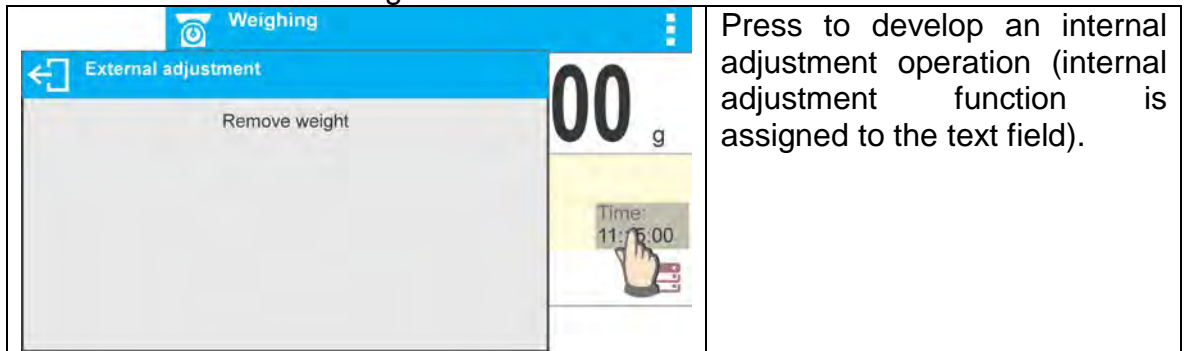

Press to develop an internal adjustment operation (internal adjustment function is assigned to the text field).

- Functions selections pictogram:

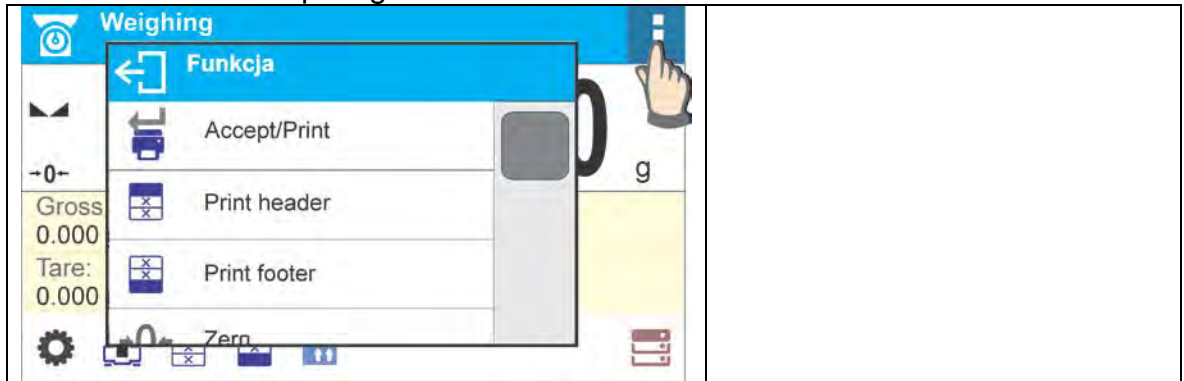

CAUTION! For instruction on configuration of buttons, labels and text fields refer to section 8.6 of this user manual.

8.5. Return to Weighing Mode

Introduced modifications are automatically saved in menu on return to the weighing mode.

| | |
|--|---|
| | |
| <p>Press soft key repeatedly, keep pressing the key until the balance home screen is displayed.</p> | <p>Press soft key located on the balance overlay for immediate display of a home screen.</p> |

8.6. Buttons, Labels and Text Fields Configuration

Area beneath weight indication section can be freely programmed. It is divided into active fields taking form of a table: 3 rows, 10 columns.

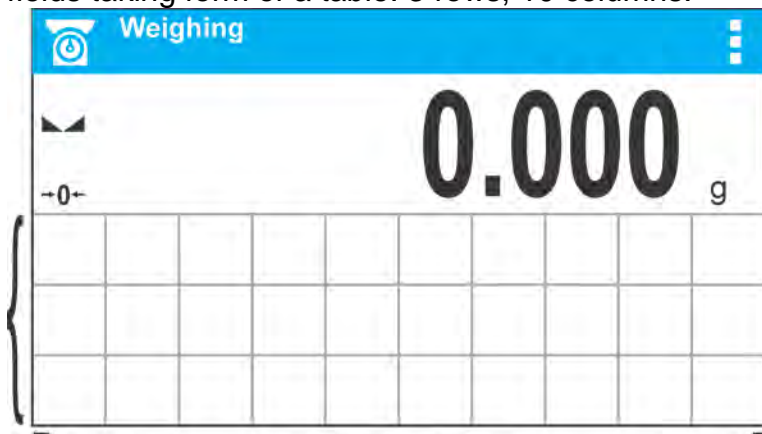

The division lines presented above are not visible on the balance screen, they serve only for informative purposes.

This section is designed to comprise user-selected widgets: buttons, labels, text fields, bargraphs:

- **button** – pictogram to which a particular function is assigned, the function is triggered upon pressing the pictogram;
- **label** – field for information, its content is stable. The content depends on displayed option, wherein the options change in course of balance operation. The label may be active or passive. Active label, when pressed, triggers function that is assigned to it, e.g. selecting product out of products database. Passive label provides you with information on current state, no function is assigned to it;
- **text field** - field for information, both content (text and variables of line 1 and 2) and function assigned to text field are programmable. The field may be active or passive. Its operation is likewise as for label, the only difference is that for the text field it is the user who specifies which function is to be assigned to it. The function does not have to refer to displayed information, e.g. the text field displaying date and time may trigger balance calibration upon being pressed;
- **bargraph** – option available for *Checkweighing* and *Dosing* modes, field providing information on Min and Max threshold - *Checkweighing* mode, and target weight - *Dosing* mode, the given information is presented in a graphic form, bargraph colour informs whether weight stays within the specified tolerance or is out of it.

The section may be set up freely in a way matching your needs. Each of the modes may be configured independently.

Set up rules:

1. Widgets dimensions (width x height)

- button – 1x1
- label – 2x1; 3x1; 4x1; 5x1
- text field – 2x1; 3x1; 4x1; 5x1; 6x1; 7x1; 8x1; 9x1; 10x1
- bargraph – 5x1; 10x1

To quickly restore the default widgets layout press the widget and hold it until a window with available options displays. Select **<Default screen settings>** and confirm.

Exemplary arrangement of widgets:

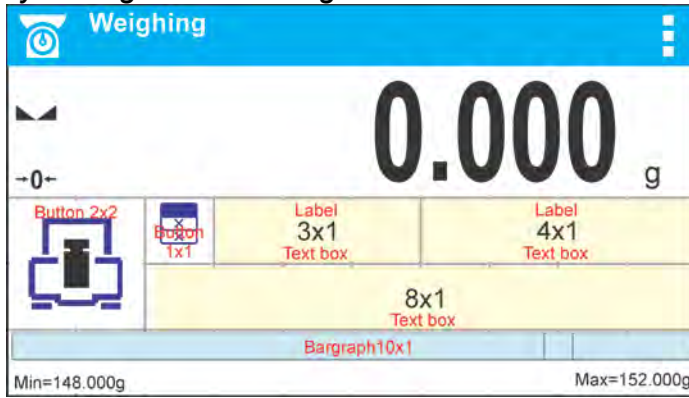

1. Always click extreme left side of a particular field that is to hold a selected <Widget>.

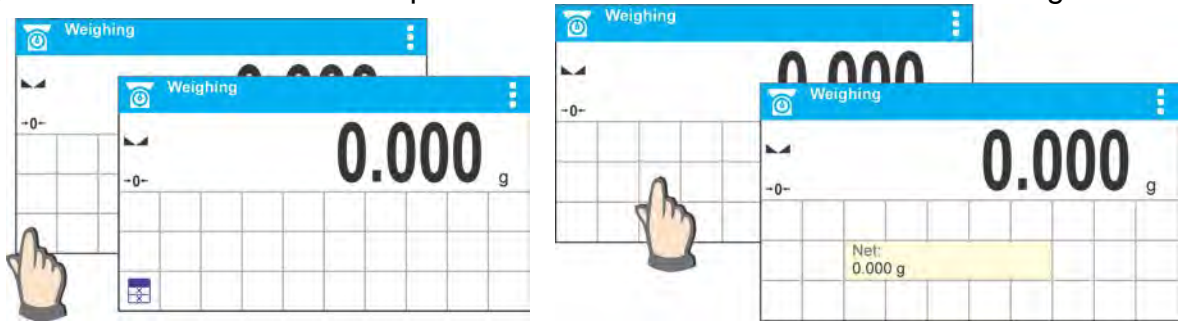

2. A new widget can only take such area that holds no other widgets yet. The software automatically detects which widgets can be applied for a particular area, this is conditioned by widget dimensions.

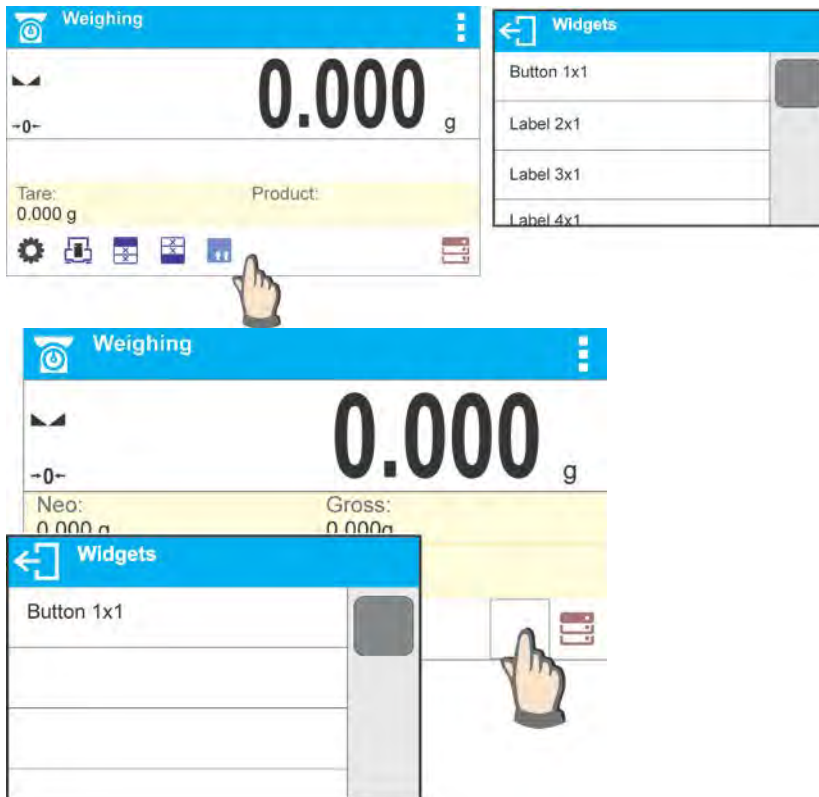

3. It is possible to change functions assigned to an already applied widget. The applied widget, if not needed, can be removed.



4. In order to rearrange widgets layout, it is necessary to delete already applied widgets first, and define new arrangement of buttons, labels and text fields next.

8.6.1. Quick Access Keys

You can define quick access keys, the keys are displayed underneath weight indication section. Quick access key provides direct access to the most frequently operated functions, it is selected from a list of available keys.





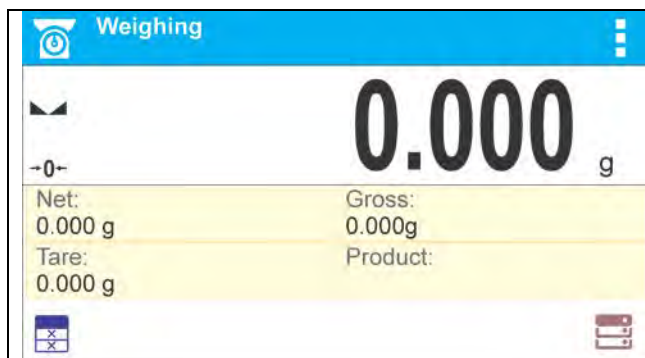













Procedure:

| | |
|--|---|
| | <p>Press and hold for a while the spot where a given key is to be placed.</p> |
| | <p>Select option: key 1x1</p> |
| | <p>Enter particular key setup.</p> |
| | <p>Select the key.</p> |



The selected key is displayed automatically on a home screen.

Quick access keys list:

| Key | Function | Modes featuring the key |
|---|-------------------------|---------------------------|
|  | Accept/Print | All modes |
|  | Print header | Weighing mode exclusively |
|  | Print footer | Weighing mode exclusively |
|  | Zero | All modes |
|  | Tare | All modes |
|  | Set tare | All modes |
|  | Change unit | Weighing mode exclusively |
|  | Select unit | Weighing mode exclusively |
|  | Parameters | All modes |
|  | Databases | All modes |
|  | User | All modes |
|  | Product | All modes |
|  | Customer | All modes |
|  | Packaging | All modes |
|  | Adjustment | All modes |
|  | Variable 1 | All modes |
|  | Variable 2 | All modes |
|  | Variable 3 | All modes |
|  | Working mode parameters | All modes |

| | | |
|--|----------------------------|---------------------------|
| | Hide/show last digit | Weighing mode exclusively |
| | Drying mode | Drying mode exclusively |
| | Drying profile | Drying mode exclusively |
| | Finish mode | Drying mode exclusively |
| | Printout interval and unit | Drying mode exclusively |
| | Open/close cover | Drying mode exclusively |
| | Start | Drying mode exclusively |

8.6.2. Labels

You can select label size and type of information to be displayed for a particular label. In order to select a particular label, use a list of available labels. Upon label selection, specify type of information to be displayed for the label. The selected label is displayed automatically on a specified home screen spot.

Procedure:

| | |
|--|--|
| | <p>Press and hold for a while the spot where a given label is to be placed.</p> |
| | <p>Select a label and its size.</p> |
| | <p>Label settings window opens, click INFORMATION field in order to see a list of information type available for the selected label.</p> |

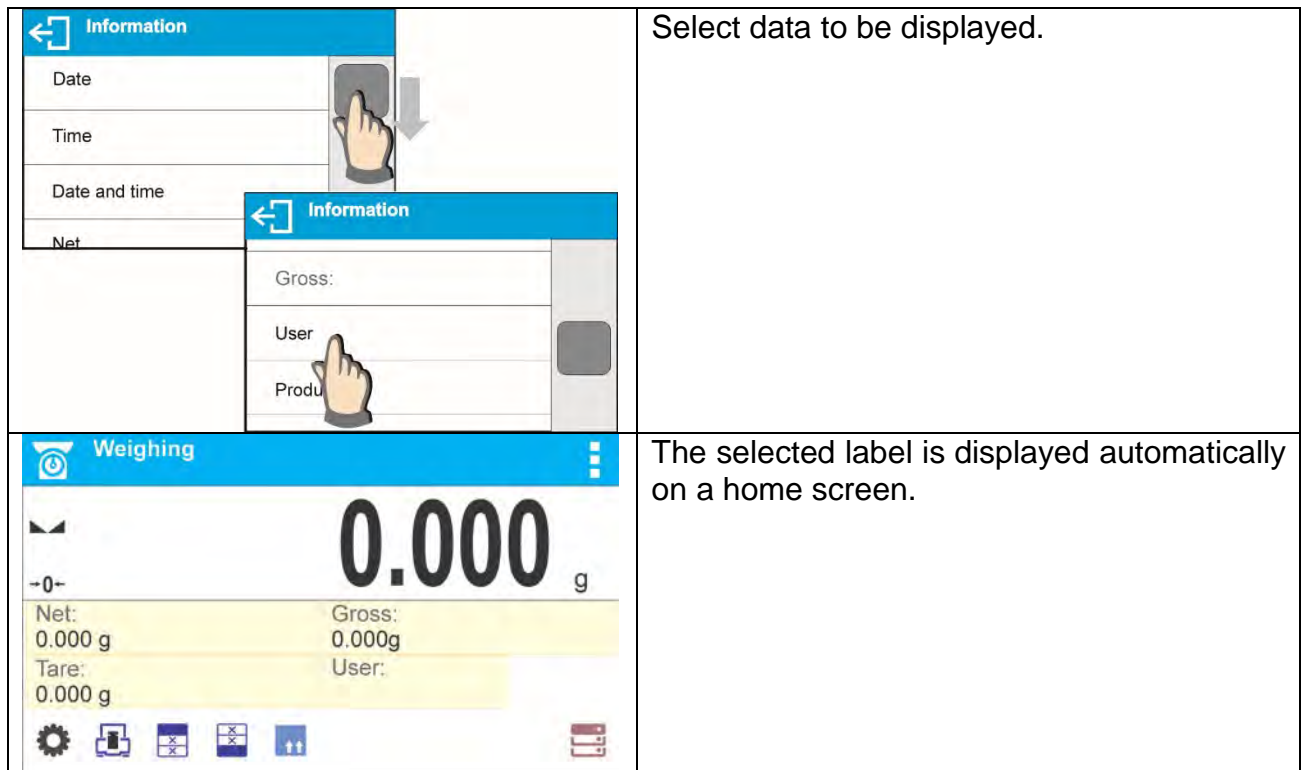

Select data to be displayed.

The selected label is displayed automatically on a home screen.

Label information types:

| Label information type | Modes featuring the information |
|-------------------------|---------------------------------|
| Date | All modes |
| Time | All modes |
| Date and time | All modes |
| Net weight | All modes |
| Tare | All modes |
| Gross weight | All modes |
| User | All modes |
| Product | All modes |
| Packaging | All modes |
| Customer | All modes |
| Variable 1 | All modes |
| Variable 2 | All modes |
| Variable 3 | All modes |
| MSW value | Weighing mode exclusively |
| MSW tare | Weighing mode exclusively |
| MSW status | Weighing mode exclusively |
| Drying mode | Drying mode exclusively |
| Drying profile | Drying mode exclusively |
| Finish mode | Drying mode exclusively |
| Printout interval | Drying mode exclusively |
| Temperature/drying time | Drying mode exclusively |
| Drying chamber status | Drying mode exclusively |

The above presented information type has been designed for particular working modes.



Detailed description for a given information type is provided within section overviewing a respective mode.

8.6.3. Text Fields

You can select text field size and type of information to be displayed in the first and the second line of the field, plus you can decide on a function that is to be assigned to a particular text field.

Upon completed setup operation, the selected text field is displayed automatically on a specified home screen spot.

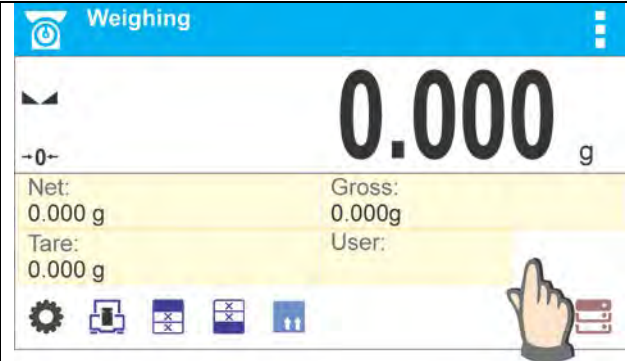
Procedure:

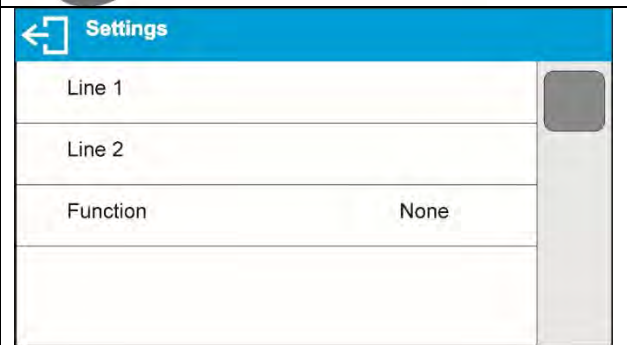
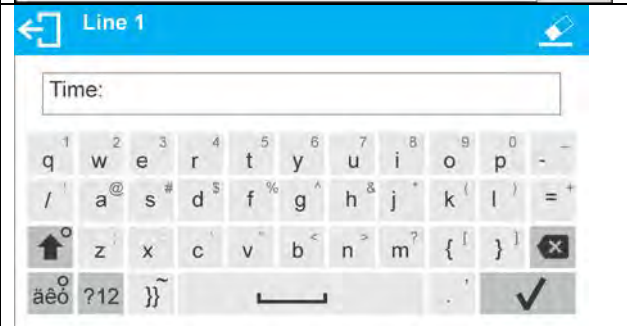
| | |
|---|---|
|  | <p>Press and hold for a while the spot where a given key is to be placed.</p> |
|  | <p>Select text field and its size.</p> |
|  | <p>Text field settings window opens. Define particular text field parameters:</p> |
|  | <p>Line 1: e.g. text <Time:>,</p> |

| | <p>Line 2: e.g. variable {3}, variable for current time displaying (other variables refer to point for non-standard printouts defining),</p> | | | | | | | | |
|---|--|-------|--------|-------|--------|-----|----------|-------------|---|
| | <p>Function: e.g. adjustment.</p> | | | | | | | | |
| <table border="1"> <thead> <tr> <th>Line</th> <th>Value</th> </tr> </thead> <tbody> <tr> <td>Line 1</td> <td>Time:</td> </tr> <tr> <td>Line 2</td> <td>{3}</td> </tr> <tr> <td>Function</td> <td>Calibration</td> </tr> </tbody> </table> | Line | Value | Line 1 | Time: | Line 2 | {3} | Function | Calibration | <p>When all text field parameters have been defined, the window displays respective values.</p> |
| Line | Value | | | | | | | | |
| Line 1 | Time: | | | | | | | | |
| Line 2 | {3} | | | | | | | | |
| Function | Calibration | | | | | | | | |
| | <p>The defined text field is displayed automatically on a home screen.</p> | | | | | | | | |

8.6.4. Bargraphs

Bargraph function is accessible for all weighing modes. The bargraph presents in a graphic form how much of balance capacity is in use. Additionally it shows Min and Max thresholds positions for Checkweighing mode, and for Dosing mode it shows target weight value along with permissible tolerance.

You can select bargraph size and turn on/off <Zoom> function. This function rescales bargraph in order to improve visualization of indication.

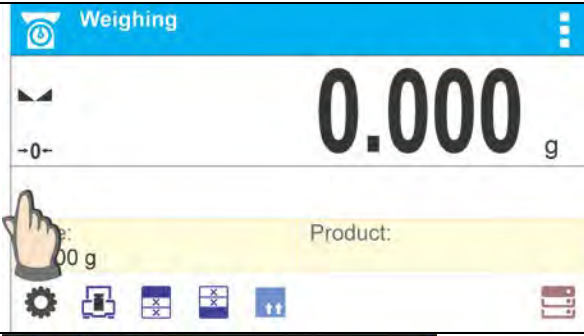
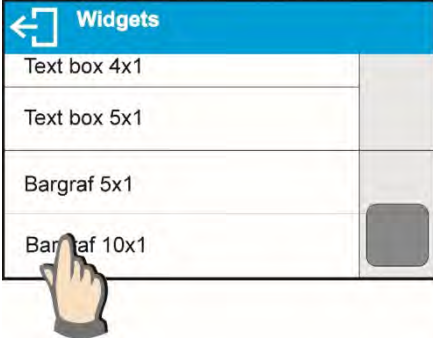
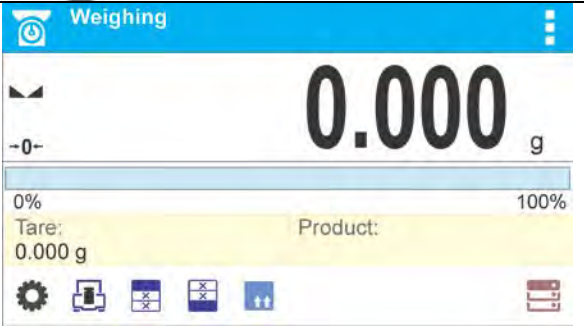

Procedure:

| | |
|--|--|
|  | <p>Press and hold for a while the spot where bargraph is to be placed.</p> |
|  | <p>Select bargraph and its size.</p> |
|  | <p>The selected bargraph is displayed automatically on a home screen.</p> |

9. WEIGHING OPERATION

Load a weighed object on a balance weighing pan. On stabilization of weighing result, indicated by stability marker  visible on the left side of balance display, read the measurement result.

Record / printout of the measurement result is available on pressing <PRINT> key:

- for verified balances – only stable measurement result can be saved or printed (stability marker  visible on balance's display),
- for non-verified balances – stable or unstable measurement result can be saved or printed (regardless of stability marker  absence). If unstable measurement result is printed then it is accompanied by question mark <?> in front of printed mass value.

9.1. Good Weighing Practice

In order to ensure long lasting use of a moisture analyzer plus correct and reliable measurement of weighed loads, follow below procedures:

- Start the balance with no load on the weighing pan (permissible value of load on the weighing pan on balance start is $\pm 10\%$ of its maximum capacity).
- Load the weighing pan steadily avoiding shocks:

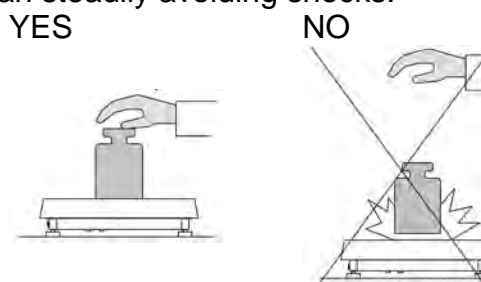

- Place weighed loads centrally on the weighing pan:



- Avoid side loading, in particular side shocks:

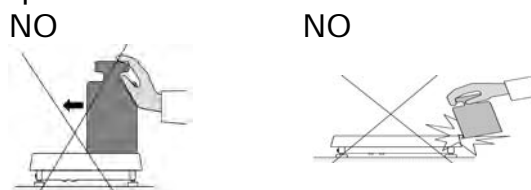

9.2. Logging

Full access to user parameters and to editing databases requires logging as an operator with **<Administrator>** permissions level. The logging procedure should be carried out on each switching on of the balance.

First Log In operation - procedure:

1. Run home screen and press  button, operators database window opens with list of available users,

2. Select **<Admin>** option, the software activates an on-screen keyboard, use it to enter operator's password: „1111”,
3. Press  button to confirm, home screen of the software is displayed again automatically,
4. When logged, add users and set the permissions levels (for the procedure of assigning permissions levels go further down this user manual).

On future Logging In, select a user from the list and enter the password, the software initiates operation with permissions level set for the selected user.

Log out operation – procedure:

1. Run home screen and press  button, operators database window opens,
2. Press **<Log out>** soft key (located as position no. 1 in the list of operators),
3. Home screen of the software is displayed again automatically.

Permissions levels

Balance software comprises three permissions levels: administrator, advanced operator, user.

Permissions level dependent access to edition of user parameters, databases and software functions:

| <i>Permissions levels</i> | <i>Enabled operations</i> |
|---------------------------|---|
| User | Free editing of parameters of <Readout/Filter> submenu. Modification of settings for <Misc.> parameter group, except for settings for <Date and Time>, <Access level> and <Software update>. The operator can start and carry out all weighing processes. The operator can preview information recorded in <Databases>, (s)he can define universal variables. |
| Advanced User | Free editing of parameters of the following submenus: <Readout>; <Working modes>; <Communication>; <Peripherals>; <Misc.>. Access to <Date and Time>, <Access level> and <Software update> submenus denied. The advanced operator can start and carry out all weighing processes. |
| Administrator | Access to all user parameters and functions, editing databases enabled. |

9.3. Units

UNITS parameter group enables you to change availability of mass units (the change can be performed in-course of balance operation), and to define two custom units, thus positively effecting comfort and speed of operation. It is possible to change unit to other than unit [g] during weighing process or during operation of other modes.

9.4. Weighing Unit Selection

Change of weighing unit is carried out by pressing the weighing unit icon visible next to the value of measurement result, or by clicking  key (if displayed in an information section).

Clicking the unit triggers its replacement, the clicked unit is replaced with the unit that is next on the list of available units.



Another option for unit replacement is selecting a particular unit out of the units list, to view the list click  key (if displayed in an information section).



Units list:

| Unit | Denotation | Verified balance | Unit | Denotation | Verified balance |
|-----------------|------------|------------------|--------------|------------|------------------|
| gram | [g] | yes | Taele Taiwan | [tlt] | no |
| miligram | [mg] | yes * | Taele China | [tlc] | no |
| kilogram | [kg] | yes * | Momme | [mom] | no |
| carat | [ct] | yes * | Grain | [gr] | no |
| pound | [lb] | no | Newton | [N] | no |
| ounce | [oz] | no | Tical | [ti] | no |
| ounce Troy | [ozt] | no | baht | [baht] | no |
| pennyweight | [dwt] | no | tola | [tola] | no |
| Taele Hongkong | [tlh] | no | mesghal | [msg] | no |
| Taele Singapore | [tls] | no | | | |

* - Accessibility of measuring units is conditioned by balance type.

9.5. Weighing Units Accessibility

You may declare which units shall be accessible while selecting a temporary unit by means of  key. Units with parameter value set to <Yes  > option are available for selection in particular working modes, i.e. modes facilitating units change.

| | |
|---|---|
|  | <p>Units with parameter value set to <No  > option will not be accessible while operating the balance.</p> |
|---|---|

9.6. Start Unit Selection

Upon selection of start unit, the balance activates with the specified start unit for these modes where change of the unit is possible.

Ability of selecting a given unit depends on the balance status, i.e. if the balance is verified or not.

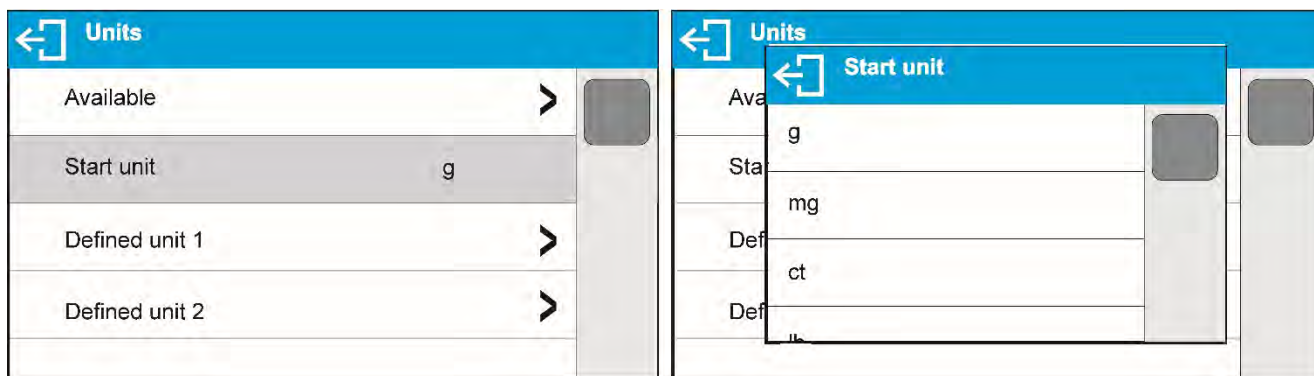

9.7. User-defined Unit

You may declare two units. Displayed value of a user-defined unit is a multiplication of measured mass value and a coefficient specified for the particular user-defined unit. The units can be freely named with use of 3 characters maximum. By default the names are displayed as **[u1]** – user unit 1, and **[u2]** – user unit 2.

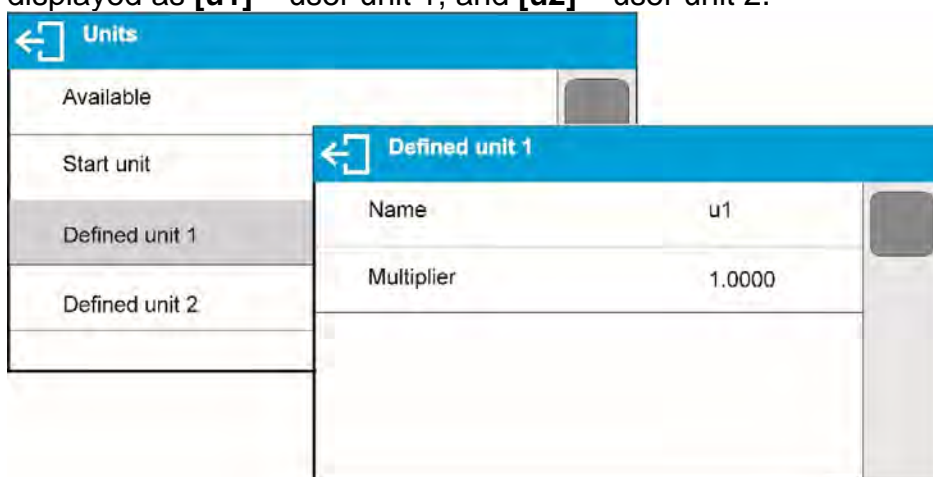

9.8. Balance Zeroing

In order to zero mass indication, press $\rightarrow 0 \leftarrow$ button. Mass indication of zero value shall be displayed together with precise zero $\rightarrow 0 \leftarrow$ and stability $\blacktriangle \blacktriangledown$ markers.

Zeroing process is an equivalent for determining new zero point, recognized by the balance as precise zero. Zeroing is possible only for stable status of display indication.

CAUTION!

Zeroing the display indication is possible only within $\pm 2\%$ range of instrument's maximum capacity. If the zeroed value is above $\pm 2\%$ of the maximum capacity, then the software indicates a respective error message.

9.9. Balance Taring

In order to determine net weight of the object, place object's container (packaging) on the weighing pan, and on stabilization of measurement result press $\rightarrow T \leftarrow$ key. The display indicates mass equal zero and symbols: Net and $\blacktriangle \blacktriangledown$. On taking off the weighed load and its packaging from the weighing pan, the display indicates sum of total tared mass with minus sign.



The software enables assigning tare value to a database-stored product. Using this option, the software automatically uploads data on tare value for a particular product upon its selection from the database.

CAUTION!

Taring negative values is impossible. On taring negative values the balance responds with an error message. In such case, zero balance indication and repeat taring procedure.

Manual Tare Determination

Procedure:

1. While in optional mode press  quick access key,
2. An on-screen numeric keyboard is displayed,
3. Enter tare value and press  key,
4. The balance returns to the weighing mode, and the display indicates entered tare value with minus '–' sign.

Deleting Tare

The tare value indicated on balance display can be deleted by pressing  key on balance overlay, or by using programmable function key <Deactivate tare>.

Procedure 1 - on taking the tared load off the weighing pan:



1. Press  key.
2. The NET marker is deleted, and new zero point of the balance is determined.

Procedure 2 - with tared load on the weighing pan:

1. Press  key.
2. The NET marker is deleted, and new zero point of the balance is determined.
3. When tare value exceeds 2% of the maximum capacity, respective message is displayed in order to inform a user about the fact.

Selecting tare value out of PACKAGINGS DATABASE

Procedure:

1. While in optional mode, press  button located in a top left hand corner of the mass display.
2. Wait for a respective window to open, next select  <PACKAGING>.
3. Window with a list of tare values recorded into tare database opens.
4. Select the packaging that is to be used.
5. The balance returns to the weighing mode, and the display indicates selected tare value with a minus '–' sign.

or

1. While in optional mode, press  button (if displayed on the screen),
2. Window with a list of tare values recorded into tare database opens.
3. Select the packaging that is to be used.
4. The balance returns to the weighing mode, and the display indicates selected tare value with a minus '–' sign.

AUTOTARE function

Autotare function provides automatic taring of the packaging during the weighing process when packaging mass for each of the product is different. For description of this function go further down this manual.

Deleting tare

Entered tare value can be deleted by pressing  button on the overlay or by entering tare value of 0.000g (see description above).

9.10. Weighing Mode Settings

The software allows setup of operating parameters (filters, value release and autozero function, deleting the last digit and other settings) separately for each working mode.

It enables customizing the instrument and utilizing its properties depending on your needs and expectations, or on specific requirements for selected working mode (e.g. DOSING); as a result the device operation is quick and easy.

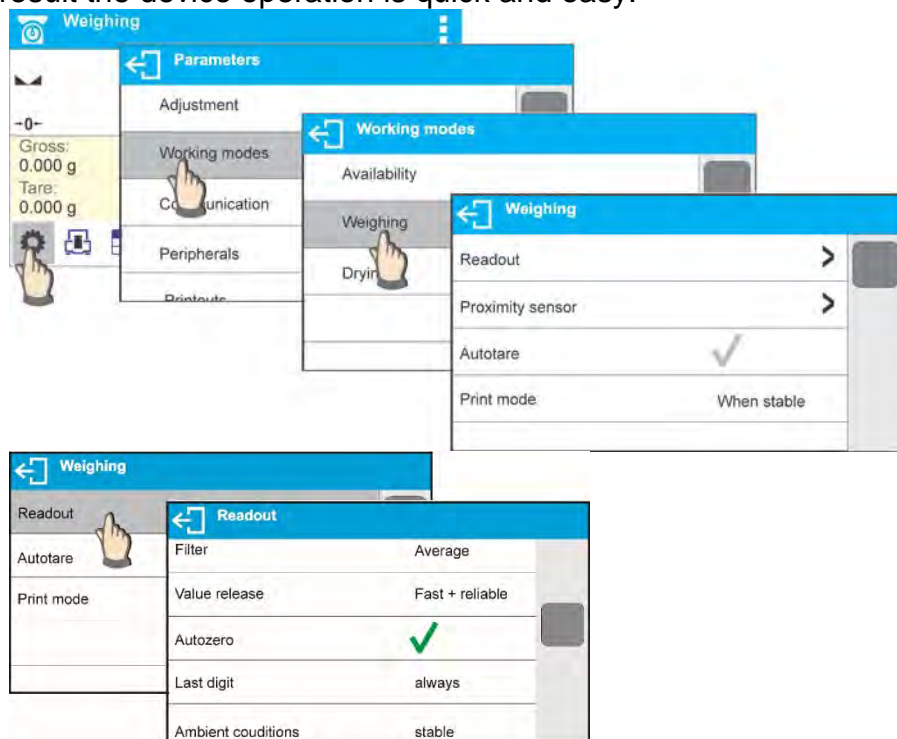

Filter level setting

Filter settings adjustment depends on the working environment. For the best possible conditions the filter can work in a very fast mode (V.FAST value for Filter parameter); however, if the conditions are poor (shakes, drafts), the filter should be set to slow or very slow option (SLOW or V. SLOW value for Filter parameter). The effectiveness of the filter is different throughout the weighing range. The filter works slower when “approaching” the weighed mass, it works more intensively for weighed mass within the set range of the filter (parameter for setting filter range is accessible only from the service menu – the user does not have any access to it).

Depending on the filter, the weighing time is shorter (V.FAST and FAST) or longer (SLOW and V. SLOW).



CAUTION!

The higher filter level, the longer weighing time.

Value release

Since ambient conditions at a workplace vary, it is necessary to determine the value release parameter in the most preferable way enabling balance adaptation, parameter options are: **FAST.+REL.**, **FAST** or **RELIABLE**. Depending on the selected option, weighing time is either shorter or longer.

Autozero function

The software features an autozero function (**Auto**) ensuring precise mass indication. This function automatically controls and corrects zero indication. When Autozero is enabled, it compares balance indications at declared time interval e.g. 1s, provided that weighing pan is unloaded and display indication is close to zero. If results vary less than declared AUTOZERO range e.g. one division, balance zeroes automatically, marker of stable measurement result – , and precise zero marker – **0** – are displayed.

If AUTOZERO function is enabled, then each weighing process starts from precise zero point. There are, however, some cases when this function can be a disturbing factor for the measuring process; e.g. very slow placing of a load on the weighing pan (load adding). Here, zero indication correction can also correct actual indication of loaded mass.

Last digit display

Function enables displaying the last digit of decimal place for a weighing result. There are three available options:

- **Always:** all digits visible,
- **Never:** last digit is not displayed,
- **When stable:** last digit is displayed only for a stable weighing result.

Balance ambient conditions

Parameter relating to ambient and environmental conditions in which the balance operates. There are two options: <STABLE> and <UNSTABLE>. Selecting <STABLE> mode makes the balance work much faster, i.e. weighing takes much less time than for <UNSTABLE> mode. If the ambient conditions are unstable it is recommended to use <UNSTABLE> mode. By default, the parameter is set to <STABLE> option.

9.11. Proximity Sensors

The balance features two proximity sensors enabling touch-free balance control.

The software detects two motions performed around the sensors:

1. Hand in a close vicinity to the left sensor **<Left sensor>**,
2. Hand in a close vicinity to the right sensor **<Right sensor>**.

Each motion can trigger optional balance function. For available functions list go to section 8.6.1. Upon completed configuration procedure, the software runs function assigned to a particular proximity sensor having detected motion around it. To provide correct operation, it is necessary to set the right proximity sensors sensitivity (*for more information go to section 10*).

9.12. AUTOTARE

Autotare is used for quick determination of net weight for loads with different tare values, wherein they are measured one after another.

When the function is active (<AUTOTARE> parameter set to <YES> option), the operating process takes the following steps:

1. Make sure that the weighing pan is empty and press button responsible for zeroing,
2. Put product packaging on a weighing pan (packaging weight value must be greater than set AUTO THRESH value),
3. After measurement stabilization, **automatic taring** of the packaging mass proceeds (**Net** marker appears in the upper part of the display),
4. Put product that is to be packed into the packaging;
5. The display shows net weight of the product;
6. Take off the product together with the packaging;

7. The balance cancels tare value (packaging weight recorded in balance storage during the first step of the operating process) after the gross mass value (set in **<AUTO THRES>** parameter) has been exceeded; the entered tare value is cancelled automatically (**Net** marker disappears from the top section of the display), net weight is displayed;
8. Put packaging of the next product on a weighing pan, automatic taring of the packaging weight proceeds after measurement stabilization (**Net** marker appears in the top section of the display);
9. Put a next product that is to be packed.

For correct operation of the balance with AUTOTARE function it is necessary to adjust the threshold value.

<AUTO THRES> parameter is connected with the following functions:



- automatic tare,
- automatic operation,

No automatic taring takes place as long as the gross weight value stays within the range set in **<AUTO THRES>** parameter.

9.13. Print Mode

Function designed to enable print mode setting, it activates  key.

Print mode options:

- **<WHEN STAB>**, for this option stable measurement result, along with the settings for parameter **<GLP PRINTOUT>**, is sent to the printer port. On pressing  key, when the result is not stable (no  marker on a display), the balance software sends the measurement result to the port after reaching stability for the measurement.
- **<EACH>**, for this option every single pressing of  button results with sending the measurement indication to the printer port along with the settings for **<GLP PRINTOUT>** parameter. Every single indication is sent (stable and unstable). For unstable indication **<?>** character appears at the beginning of the printing frame.

This function applies to non-verified balances exclusively.

- **<AUTO>** - select this option to enable automatic printing of measurements. If this option has been selected, remember to set **<AUTO THRES>** parameter to suit your needs.
- **<AUTO+INT.>** select this option to start automatic printout and record of indications in Weighings database and Alibi database, carried out in a cyclic manner in a specified time interval. The interval is set in minutes, in **<AUTO INT.>** parameter. Interval range is 1-9999 min.



CAUTION!

Each result is printed and recorded (stable and unstable for a non-verified balance, stable for a verified balance).

Automatic operation with interval starts at the moment of switching the function on and it lasts until it is switched off. The first stable weighing result of value greater than AUTO THRES value is printed as a first measurement. The following measurements are printed with frequency set in INTERVAL parameter. Automatic operation with interval stops when the option is off.

On switching the function of auto print with interval, PRINT button becomes inoperative (no indication is printed when pressed).

Automatic operation procedure:

1. Press  button to zero the balance (marker of stable measurement  and zero marker **-0-** are shown on a display),
2. Deposit load, the balance sends the first stable measurement to the printer port,

3. Remove the load from the pan,
4. Next measurement is possible when the indication is lower than the set value of <AUTO THRES.> parameter (next measurement does not require zero value).

For automatic operation adjust the threshold value. The measurement will not be send from the computer to the printer as long as the mass measurement stays within the set value range <AUTO THRES>.

<AUTO THRES> parameter is connected with the following functions:

- automatic tare,
- automatic operation,
- auto with interval.

9.14. Minimum Sample Weight

Weighing mode comprises <Minimum sample weight> function. In order to use this function it is necessary to enter minimum sample weight (MSW) value and tare values for which the MSW value is to be obligatory. For standard X2 series models the values equal zero.

Only authorized RADWAG employee or operator with Administrator permissions level, providing that balance factory settings enable this, can carry out procedure aiming to determine minimum sample weight and next enter the respective data.

If you want to use this function, and your balance menu contains no minimum sample weight data, ask the nearest RADWAG office for help.

Authorized RADWAG employee determines minimum sample weight for specified tare containers. The determination is carried out using mass standards on site, requirements of applied quality system are adhered to. Obtained value is entered into software, <Minimum sample weight>.

Balance software enables defining tare value with assigned minimum sample weight value. <Minimum sample weight> function guarantees that results of weighing operation are comprised within set tolerance, accordant to applied quality management system of particular company.

CAUTION!

This function is valid for weighing mode exclusively.

Options:

- **MODE**
 - None** – minimum sample weight function off
 - Block** – select to make the balance display respective pictograms informing on mass (whether it is out-of-tolerance low or out-of-tolerance high); with this option on, the software disables confirmation of the measurement that is out-of-tolerance low
 - Warn** – select to make the balance display respective pictograms informing on mass (whether it is out-of-tolerance low or out-of-tolerance high); with this option on, the software enables confirmation of the measurement that is out-of-tolerance low
- **Tare** – maximum tare value for which minimum sample weight value is obligatory (read examples below)
- **Minimum mass** – minimum sample weight determined for particular balance on site using respective method.

Example 1 for balance with d=0.0001 g:

| No. | Tare value | Minimum Sample Weight | Operation |
|-----|------------|-----------------------|--|
| 2 | 10.0000 g | 1.0000 g | Minimum sample weight refers to all net weights subjected to weighing in a tare container of mass 0,0001g – 9,9999g inclusive (<TARE> button used). The program identifies setting specifying that minimum sample weight is valid exclusively for samples weighed in a tare container of weight covered by the above specified range. If taring function is not used or tare container weight is covered by range 10,0000g – Max, then pictogram informing on use of minimum sample weight goes blank. |

Example no. 2 for balance with d=0.0001 g:

| No. | Tare value | Minimum Sample Weight | Operation |
|-----|------------|-----------------------|--|
| 1 | 220.0000 g | 0.5000 g | Minimum sample weight refers to all net weights subjected to weighing in a tare container of mass covered by full weighing range (<TARE> button used). The program identifies setting specifying that minimum sample weight is valid exclusively for samples weighed in a tare container. If taring function is not used, then pictogram informing on use of minimum sample weight goes blank. |

Example no. 3 for balance with d=0.0001 g:

| No. | Tare value | Minimum Sample Weight | Operation |
|-----|------------|-----------------------|---|
| 1 | 0.0000 g | 0.2500 g | Minimum sample weight refers to all net weights subjected to weighing where no tare container is used (<TARE> button not used). The program identifies setting specifying that minimum sample weight is valid exclusively for samples not weighed in a tare container. If taring function is used, then pictogram informing on use of minimum sample weight goes blank. |

As a user you can preview entered data, but you are not allowed to edit it.

Weighing with use of <MINIMUM SAMPLE WEIGHT> function

If in course of weighing you want to obtain information stating whether particular measurement is out-of-tolerance high, specified for minimum sample weight, then <Minimum sample weight> function shall be on, to turn the function on go to Weighing mode settings.

Procedure (Administrator exclusively):

1. Enter weighing mode settings,
2. Press <Minimum sample weight> field,
3. Press <Mode> field,
4. Settings window is displayed with the following options:

Block – select to make the balance display respective pictograms informing on mass (whether it is out-of-tolerance low or out-of-tolerance high); with this option on, the software disables confirmation of the measurement that is out-of-tolerance low,
Warn – select to make the balance display respective pictograms informing on mass (whether it is out-of-tolerance low or out-of-tolerance high); with this option on, the software enables confirmation of the measurement that is out-of-tolerance low.

5. Select respective option and return to the home screen,
6. Section presenting the weighing result comprises additional pictogram providing supplementary information. The pictogram changes in course of weighing operation informing you on the weighed sample mass with reference to declared minimum sample weight value

| | |
|---|--|
| | |
| <p>Weight value lower than minimum sample weight specified for a particular tare range.</p> | <p>Weight value higher than minimum sample weight specified for a particular tare range.</p> |

Pictograms for minimum sample weight:

| | |
|--|--|
| | <p>Weight value lower than specified minimum sample weight.</p> |
| | <p>Weight value higher than or equal to specified minimum sample weight.</p> |

CAUTION!

If more than one reference tare value has been programmed (along with min load values assigned to them) then indicated value automatically turns to range respective for tare container weight. Requested minimum load changes simultaneously.

9.15. Cooperation with TITRATORS

In order to provide correct cooperation with Titrators, go to settings of standard printout content and set <Mass value for a titrator> parameter to <Yes> value. With this, other variables for the printout are turned off.

| | |
|--|--|
| | |
|--|--|

With <Yes> value on, a respective pictogram is displayed in the top bar of a home screen. The pictogram informs on special format of mass printout, tolerable by TITRATORS.

10. MISCELLANEOUS

A user can set up parameters which influence balance operation. These parameters are to be found in parameters group **MISC**.

Settings modification for particular parameters of this parameter group proceeds likewise as described in section 8 of this user manual.

Menu language

Language parameter enables selecting the language of the balance menu descriptions for unlogged user.

Available languages: POLISH, ENGLISH

In order to change menu default language for unlogged user select new language (**Setup/Misc./Language**) and restart the balance.

Permissions

Permissions parameter enables choosing access level for a particular user, one that is not logged in.

Available access levels: ADMIN. / USER. / ADV.

Depending on selected permissions level, you can enter balance parameters and modify the settings, as far as possible for a particular level. Logging in operation is not required (for permissions overview go to section 9 of this user manual).

„Beep” sound – reaction to operation of pressing a key

Sound parameter enables switching on/off a ‘beep’ sound responsible for informing a user about pressing any key of balance overlay or display, or about proximity sensors response.

Procedure:

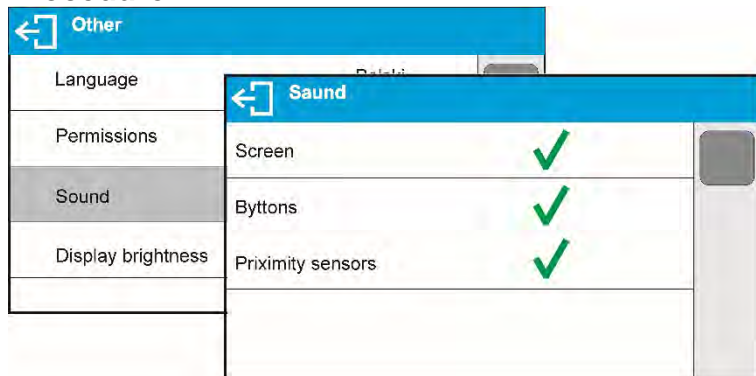

Backlight and adjusting display brightness

Display brightness parameter enables setting the brightness of the backlight or switching off the display brightness completely.

Procedure:

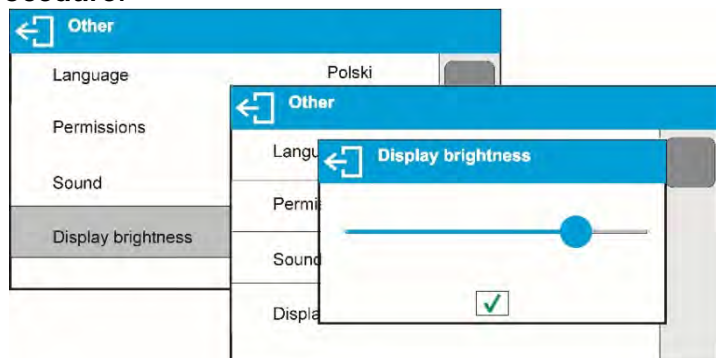

Proximity sensors sensitivity adjustment

Proximity sensors sensitivity parameter specifies distance within which the sensors can be operated, its scale is expressed in percent and it ranges from 0% to 100%. For lower percent value the proximity sensors operate at a shorter distance.

Procedure:

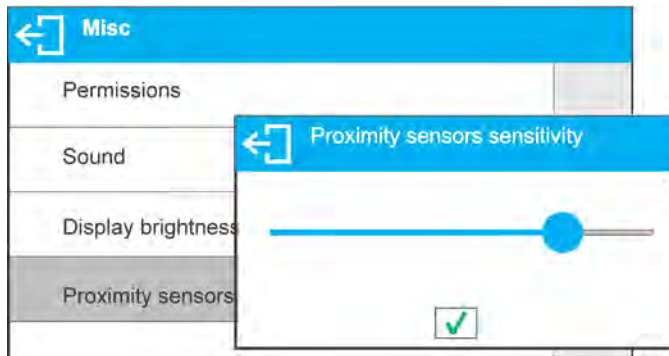

Date

Date parameter enables setting the current date.

Procedure:

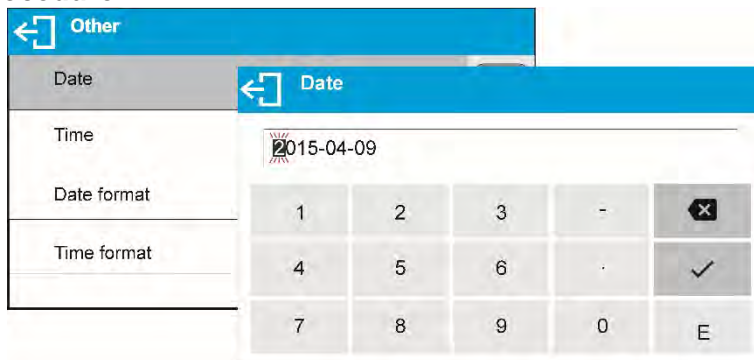

Time

Time parameter enables setting the current time. Procedures for change of time settings and date settings are likewise.

Date format

Date form. parameter enables altering the date format on the printout [YYYY.MM.DD / YYYY.DD.MM / DD.MM.YYYY / MM.DD.YYYY], where: YYYY – year; MM – month; DD – day.

Time format

Time form. parameter enables specifying time format for a printout [12h / 24h].

For [12h] option selected, <A> or <P> letter is displayed next to presented time value, where: **A** stands for hours before noon; **P** stands for hours after noon. **AM** and **PM** will be printed near to the time.

Backlight turn-off time

<BACKLIGHT OFF> parameter enables activation of display stand-by mode, the stand-by mode is activated when no weighing process is carried out (stable indication is a necessary condition for activation of the stand-by mode).

NONE – backlit turn-off time not activated.

0.5; 1; 2; 3; 5 – time given in minutes.

If the software registers stable indication for a specified time interval, set in parameter <BACKLIGHT OFF>, than the display goes out immediately. The backlight activates upon

change of indication (no stability pictogram on the display) or pressing any key on the balance keypad. The display remains blank also when balance menu is entered.

Auto switch-off

<AUTO OFF> parameter enables automatic display deactivation (the parameter functioning is likewise to  button functioning). Upon display deactivation the other subassemblies are powered and the balance turns to stand-by mode.

NONE – auto switch-off not activated.

0.5; 1; 2; 3; 5 – time given in minutes.

If the software registers stable indication for a specified time interval, set in parameter <AUTO OFF>, than the display is turned-off immediately.

To start-up the balance, it is necessary to press  button located on the balance keypad. The balance automatically returns to weighing operation.

Balance cannot be turned off if any process is started or if balance menu is entered.

11. ADJUSTMENT

In order to ensure the highest weighing accuracy, it is recommended to periodically introduce a corrective factor of indications to balance memory, the said factor must be referred to a mass standard. In other words, balance adjustment shall be performed from time to time.

Adjustment should be carried out:

- Before the beginning of weighing procedure,
- If long breaks between following measuring series occur,
- If temperature inside the balance changes more than: 2°C.

Adjustment type:

Adjustment with an external weight of declared mass which cannot be modified or of any mass, but not lower than 30% of maximum range.



CAUTION!



Remember to carry out the adjustment process when there is no load on the pan! When the weighing pan is loaded, command **<RANGE EXCEEDED>** is displayed. In such a case remove the load and

restart the the adjustment process. Adjustment process can be aborted if necessary by pressing  button at any time during the process.

11.1. External Adjustment

External adjustment is carried out by means of an external mass standard of specified accuracy class and weight. The process takes semi-automatic form, successive stages are signalled with prompts.

Procedure:

1. Enter <Adjustment> submenu, next select <External adjustment> option,
2. "Remove weight" prompt is displayed.
3. Take the weight off the weighing pan and press  button. Whereas balance determines start mass, "Adjustment; Please wait..." prompt is displayed,
4. Upon completed start mass determination procedure <Put weight ...> prompt is displayed along with particular mass standard value.
5. Put the required weigh on a pan and press  button,

6. Upon completed procedure “Remove weight” prompt is displayed.
7. Take the weight off the weighing pan, wait for <Adjustment> window to be displayed again.

11.2. User Adjustment

User adjustment is carried out with an optional standard of mass ranging between 0,3 Max and Max. User adjustment and external adjustment procedures are likewise with one exception, before user adjustment start, a message box for entering mass of a standard used for user adjustment is opened.

In order to start user adjustment, enter <Adjustment> submenu and select <User adjustment> parameter. Then follow the commands displayed on a screen.

11.3. Report Printout

Adjustment report is generated automatically at the end of each adjustment process or adjustment test and next it is sent to communication port assigned for PERIPHERAL DEVICES/PRINTER (by default it is COM1). Report content is declared in PRINTOUTS/ADJUSTMENT REPORT menu. Instruction on how to declare settings for this option is to be found further down this manual, read sections referring to printouts.

The report can be printed using balance-connected printer or sent to a computer and saved for archiving purposes as a file.

11.4. Temperature Adjustment

Temperature adjustment is carried out with a dedicated kit, that is an optional equipment of the moisture analyzer MA X2 series.

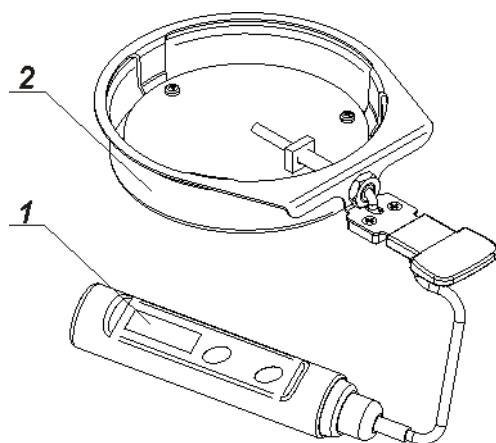

1. Thermometer
2. Thermometer holder and drying chamber shield

Adjustment of the drying chamber temperature is a process carried out for the purpose of adjusting the temperature sensor assembled inside the drying chamber of a moisture analyzer. Before starting temperature adjustment process, place the temperature calibration kit inside the drying chamber, following below diagrams:

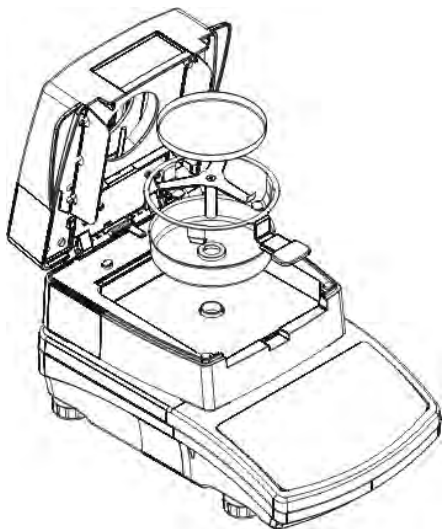

Step 1.

Remove from the drying chamber the following:

- disposable pan
- drying pan handle
- cross-shaped holder
- drying chamber insert

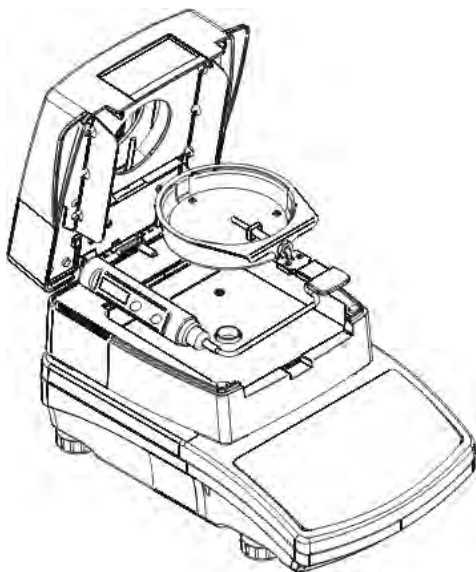

Step 2.

Assemble in the drying pan the components of temperature adjustment kit:

- drying chamber shield
thermometer holder and the
thermometer

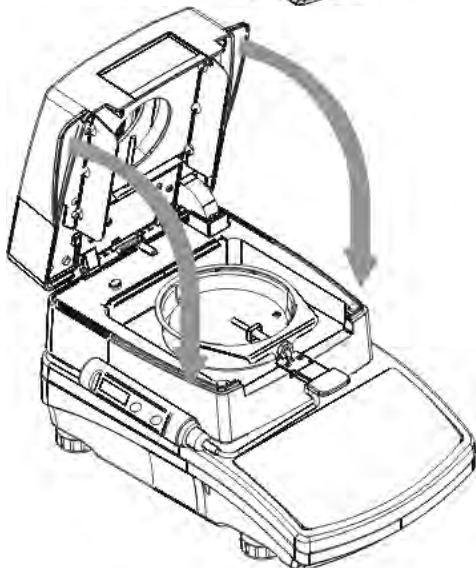

Step 3.

After assembling the kit start temperature adjustment process.

CAUTION!

All the activities must be carried out with great caution not to damage the measuring mechanism of the moisture analyzer.

Go to menu **<Temperature adjustment>** a message **<Continue?>** shall be displayed, upon its confirmation temperature sensor adjustment starts. Follow the displayed prompts. After 8 minutes a numeric keyboard is displayed. Enter the moisture analyzer temperature that is displayed on the control thermometer.

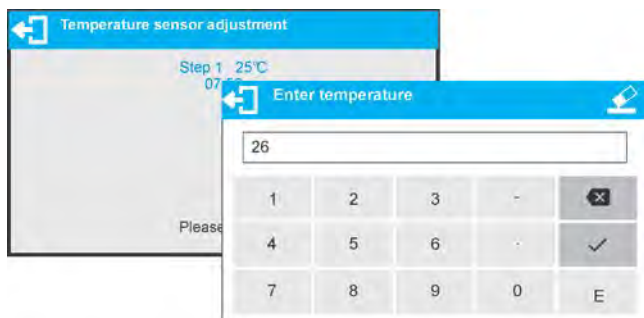

Press **✓** key to confirm, the second step of adjustment starts. The moisture analyzer halogen lamp starts to operate and the drying chamber is heated as long as necessary to provide specified temperature, which is next maintained for 8 minutes. After 8 minutes a numeric keyboard is displayed. Enter the moisture analyzer temperature that is displayed on the control thermometer.

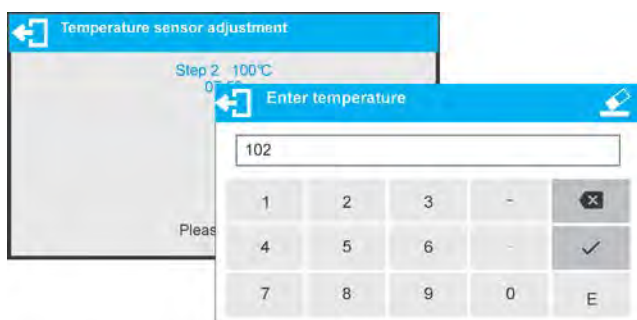

Press **✓** key to confirm, the third step of adjustment starts. The moisture analyzer halogen lamp starts to operate and the drying chamber is heated as long as necessary to provide specified temperature, which is next maintained for 8 minutes. After 8 minutes a numeric keyboard is displayed. Enter the moisture analyzer temperature that is displayed on the control thermometer.

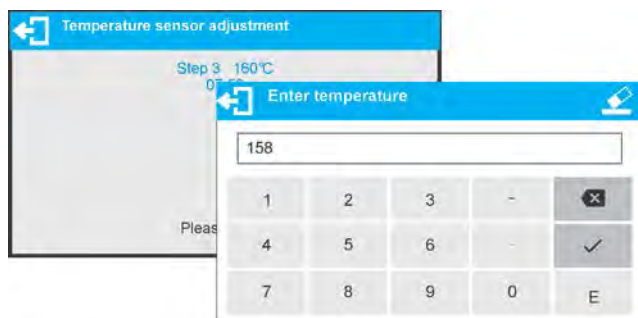

Press **✓** key to confirm. Temperature adjustment process is completed and moisture analyzer displays <Adjustment> window. For moisture analyzers with maximum heating temperature of 250 °C, the temperature adjustment process is likewise, only the temperature values are higher for each part of the process.

11.5. Drying Process Test

In order to test the drying chamber and the drying process you need to use a special adjustment set (thermometer and the thermometer holder). The set is an optional accessory of a moisture analyzer (the same that is used for temperature adjustment of the drying chamber). For information on how to assemble the set go to *Temperature adjustment section*.

Procedure:

1. Set test parameters in accordance with instruction below and the displayed prompts.
2. Enter ADJUSTMENT menu and start <Temperature test> procedure.

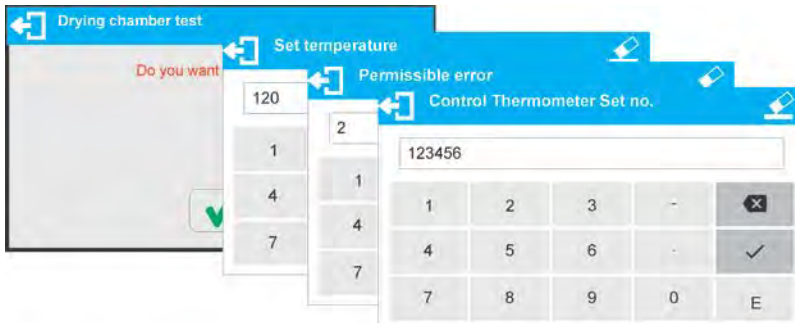

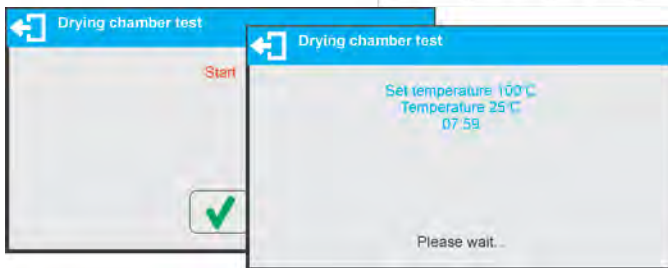

Enter:

- testing temperature
- permissible error
- serial number of the temperature adjustment set

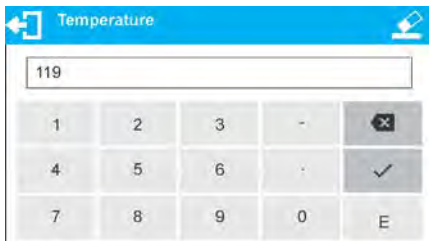

Upon confirmation of serial number START message is displayed. Press  key to confirm. The drying process starts and continues until specified temperature is reached. Time and sensor temperature information is displayed.



The temperature is maintained for 8 minutes (like for temperature adjustment procedure). After 8 minutes you shall see a window for entering temperature read from the installed adjustment set. Press  to confirm.

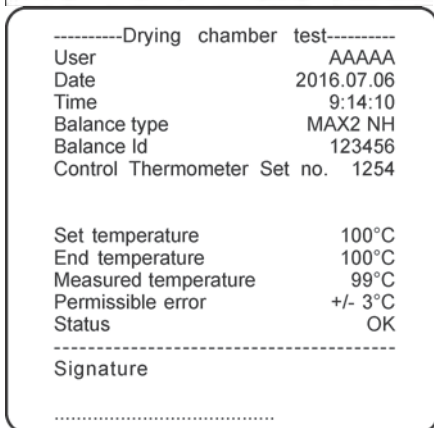

The result of the test may be printed on a printer connected to the balance. Look left to see an example of a report.

12. DETERMINING PRINTOUT CONTENT

12.1. Adjustment Report

ADJUSTMENT REPORT is a group of parameters enabling to declare data that is to be printed on an adjustment printout.

| Calibration report | |
|--------------------|-------------------------------------|
| Project | <input checked="" type="checkbox"/> |
| Calibration type | <input checked="" type="checkbox"/> |
| User | <input checked="" type="checkbox"/> |
| Project | <input checked="" type="checkbox"/> |
| Date | <input checked="" type="checkbox"/> |

| Variable | Overview |
|--------------------|---|
| PROJECT | Option enables naming the project (name associated with a particular type of weighing). The name may consist of maximum 31 characters. |
| CALIB TYPE | Option enables printing out the type of the adjustment being carried out. |
| USER | Option enables printing out the name of a logged-in user. |
| PROJECT | Option enables printing out the name of the project (see parameter Project). |
| DATE | Option enables printing out the date of the carried out adjustment. |
| TIME | Option enables printing out the time of the carried out adjustment. |
| BALANCE ID | Option enables printing out the balance ID number. |
| CAL. DIFFER | Option enables printing out the difference between mass of an adjustment weight measured during the last adjustment and the current measured mass of this weight. |
| DASHES | Option enables printing out dashes that separate the date of a printout from a signature. |
| SIGNATURE | Option enables providing an area for the signature of a user performing the adjustment. |

- **Procedure for naming the project**

| Calibration report | |
|--------------------|--------------------------|
| Project | <input type="checkbox"/> |
| Calibration type | <input type="checkbox"/> |
| User | <input type="checkbox"/> |
| Project | <input type="checkbox"/> |
| Date | <input type="checkbox"/> |

Project: PRJ/23-04/2015

For the parameters described above, one of these values must be selected:

NO - do not print

YES - print

An exemplary report:

```



-----Adjustment report-----
Adjustment type      External
User                 AAAAAA
Project              1234/qwas
Date                 2016.07.06
Time                 10:02:00
Balance Id           123456
Adjustment result difference 0.001 g
-----
Signature
    
```

12.2. Drying Process Report Printout

Group of parameters enabling user to declare data that is to be printed on a Drying Process Report printout.

The Drying Process Report is divided into three individually customized sections: the header, the measurement, the footer.

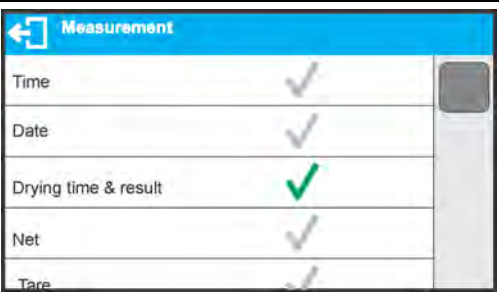
The settings are valid for Drying Process mode exclusively.

| | | |
|--------------------|---|--|
| HEADER | Group of parameters enabling to declare data that is to be printed on a header printout. |  |
| MEASUREMENT | Group of parameters enabling to declare data that is to be printed on a drying process result printout. |  |
| FOOTER | Group of parameters enabling to declare data that is to be printed on a footer printout. |  |

Printout variables list:

| <i>Variable</i> | <i>Overview</i> | <i>Active for:</i> |
|---------------------|---|--------------------|
| DATE | Option enables printing out the date of drying process start | Header |
| TIME | Option enables printing out the time of drying process start | Header |
| BALANCE TYPE | Option enables printing out the balance type. | Header |
| BALANCE ID | Option enables printing out the balance ID number. | Header |
| USER | Option enables printing out the name of a logged-in user. | Header |
| PRODUCT | Option enables printing out the name of a currently selected product. | Header |
| PROGRAM | Option enables printing out the name of a currently selected drying mode. | Header |
| DRY. PARAM. | Option enables printing out the drying parameters with accordance to which the sample is to be dried. | Header |
| VARIABLE 1 | Option enables printing out the value of VARIABLE 1. | Header |
| VARIABLE 2 | Option enables printing out the value of | Header |

| | | |
|-----------------------------------|--|------------------|
| | VARIABLE 2. | |
| VARIABLE 3 | Option enables printing out the value of VARIABLE 3. | Header |
| START MASS | Option enables printing out net weight value in a basic unit (calibration unit). | Header |
| EMPTY LINE | Option enables printing out an empty separating line. | Header Footer |
| TIME | Option enables printing out the drying time with preset interval during drying process. | GLP printout |
| INDICATION | Option enables printing out the drying process indication with preset interval during drying process. | GLP printout |
| DRYING TIME AND INDICATION | Option enables printing out time and indication with preset interval during drying process. | GLP printout |
| NET | Option enables printing out net weight value with preset interval during drying process. | GLP printout |
| TARE | Option enables printing out tare value with preset interval during drying process. | GLP printout |
| GROSS | Option enables printing out gross weight value with preset interval during drying process. | GLP printout |
| SET TEMPERATURE | Option enables printing out temperature set in a particular stage of the drying process with preset interval during the process. | GLP printout |
| CURRENT TEMPERATURE | Option enables printing out current temperature read from the sensor with preset interval during drying process. | GLP printout |
| STATUS | Option enables printing out the status of drying process summary (Completed/Aborted). | Footer |
| END DATE | Option enables printing out the end date of the drying process. | Footer |
| END TIME | Option enables printing out the end time of the drying process. | Footer |
| DRYING TIME | Option enables printing out the total time of the drying process. | Footer |
| END MASS | Option enables printing out the end mass of the tested sample. | Footer |
| INDICATION | Option enables printing out the final indication of the drying process. | Footer |
| SIGNATURE | Option enables providing an area for the signature of a user performing the measurement. | Footer |
| NSTD. PRNT. | Option enables printing out one of 100 non-standard printouts on the footer printout. You can choose one of the following options: NONE / non-standard printout name. The way of entering non-standard printouts is described further down this user manual. | Header Footer |



For the parameters described above, one of these values must be selected:

NO - do not print
YES - print

CAUTION!

For exemplary printout of a report go to section 19 of this user manual.

12.3. Other Printouts

| | | |
|---------------------|--|---|
| HEADER | Group of parameters enabling to declare data that is to be printed on a header printout. |  |
| GLP PRINTOUT | Group of parameters enabling to declare data that is to be printed on a measurement result printout. |  |
| FOOTER | Group of parameters enabling to declare data that is to be printed on a footer printout. |  |

Printout variables list:

| <i>Variable</i> | <i>Overview</i> | <i>Active for</i> |
|---------------------|---|----------------------------------|
| WORKING MODE | Option enables printing out the name of a working mode. | Header Footer |
| BALANCE TYPE | Option enables printing out the balance type. | Header Footer |
| BALANCE ID | Option enables printing out the balance ID number. | Header Footer |
| USER | Option enables printing out the name of a logged-in user. | Header GLP printout Footer |
| PRODUCT | Option enables printing out the name of a currently selected product. | Header GLP printout Footer |
| CUSTOMER | Option enables printing out the name of a currently selected customer. | Header GLP printout Footer |
| PACKAGING | Option enables printing out the name of a currently selected packaging. | GLP printout |
| DATE | Option enables printing out the date of the carried out adjustment. | Header GLP printout Footer |
| TIME | Option enables printing out the time of the printout. | Header GLP printout Footer |
| VARIABLE 1 | Option enables printing out the value of VARIABLE 1. | Header GLP printout Footer |
| VARIABLE 2 | Option enables printing out the value of VARIABLE | Header |

| | | |
|--------------------------|--|----------------------------------|
| | 2. | GLP printout Footer |
| VARIABLE 3 | Option enables printing out the value of VARIABLE 3. | Header GLP printout Footer |
| NET | Option enables printing out net weight value in a basic unit (calibration unit). | GLP printout |
| TARE | Option enables printing out the tare value in the current unit. | GLP printout |
| GROSS | Option enables printing out the gross mass value in the current unit. | GLP printout |
| CURR.RES | Option enables printing out the current measurement result (NET weight) in a current unit. | GLP printout |
| MSW WEIGHT | Option enables printing out the minimum sample weight value declared for a balance. | GLP printout |
| MSW TARE | Option enables printing out the tare value for minimum sample weight. | GLP printout |
| MASS TITRATOR FOR | Option enables printing out the net mass set for correct cooperation with titrators. | GLP printout |
| ADJUSTMENT REPORT | Option enables printing out the report of the last adjustment in accordance with the settings declared for adjustment report printout (for more information go to section 11.1 of this user manual. | Header GLP printout Footer |
| DASHES | Option enables printing out separating dashes. | Header Footer |
| EMPTY LINE | Option enables printing out an empty separating line. | Header Footer |
| SIGNATURE | Option enables providing an area for the signature of a user performing the adjustment. | Footer |
| NSTD. PRNT. | Option enables printing out one of 100 non-standard printouts on the footer printout. You can choose one of the following options: NONE / non-standard printout name. The way of entering non-standard printouts is described further down this user manual. | Header GLP printout Footer |

For the parameters described above, one of these values must be selected:

NO - do not print
YES - print

Exemplary printouts:

```

-----
Working mode      Weighing
Date              2016.07.06
Time              10:51:05
Balance type      MAX2 NP
Balance Id        123456
User              AAAAAA
Product           TTTT

```

Header

```

Date              2016.07.06
Time              10:51:05
Product           10.253 g

```

GLP Printout

```

Date              2016.07.06
Time              10:02:00
User              AAAAAA
Balance Id        123456

Signature
.....

```

Footer

12.4. Non-standard Printouts

The balance software enables entering 100 non-standard printouts. Each of them can consist of approximately 1900 characters.

Non-standard printout may include:

- variables dependent on the working mode and other needs (mass, date etc.)
- permanent text from the user menu.

Non-standard printout can have approximately 1900 characters.

12.4.1. Inserting Texts

Variables list:

| Symbol | Description |
|--------|---|
| {0} 1) | Standard printout in a calibration unit |
| {1} 1) | Standard printout in a current unit |
| {2} | Date |
| {3} | Time |
| {4} | Date and time |
| {5} | Working mode |
| {6} | Net weight in a current unit |
| {7} | Net weight in a calibration unit |
| {8} | Gross weight in a calibration unit |
| {9} | Tare in a calibration unit |
| | |
| {10} | Current unit |
| {11} | Calibration unit |
| {12} | Min threshold |
| {13} | Max threshold |
| | |
| {32} | Factory no. |
| | |
| {45} | Target value |
| {46} | Tolerance |
| | |
| {50} | Product: Name |
| {51} | Product: Code |
| {52} | Product: EAN code |
| {53} | Product: Mass |
| {54} | Product: Tare |
| | |

| | |
|-------|--|
| {56} | Product: Minimum |
| {57} | Product: Maximum |
| | |
| {66} | Product: Tolerance |
| | |
| {70} | Variable 1 |
| {71} | Variable 2 |
| {72} | Variable 3 |
| | |
| {75} | User: Name |
| {76} | User: Code |
| {77} | User: Access level |
| | |
| {80} | Packaging: Name |
| {81} | Packaging: Code |
| {82} | Packaging: Mass |
| | |
| {85} | Customer: Name |
| {86} | Customer: Code |
| {87} | Customer: VAT no. |
| {88} | Customer: Address |
| {89} | Customer: Postal code |
| {90} | Customer: City |
| | |
| {146} | Gross weight in current unit |
| {147} | Tare weight in current unit |
| | |
| {150} | Form feed for PCL printers |
| {151} | Paper crop for EPSON printers |
| | |
| {155} | Cooperation with RADWAG CONECT PC software |
| | |
| {275} | Ambient conditions readout date and time |
| {276} | THB: Temperature |
| {277} | THB: Humidity |
| {278} | Internal sensor: Temperature 1 |

| | |
|-------|--|
| {280} | THB: Pressure |
| {281} | Air density |
| {284} | THB: Temperature from an additional sensor |
| | |
| {380} | Drying mode: Name |
| {381} | Drying mode: Code |
| | |
| {385} | Drying profile |
| {386} | Drying profile parameters |
| {387} | Finish mode |
| {388} | Finish mode parameters |
| {389} | Report from drying proces: Unit |
| {390} | Report from drying proces: Printout interval |
| {395} | Moisture analyzer: Set temperature |
| {396} | Moisture analyzer: Current temperature |
| {397} | Moisture analyzer: Drying time |
| {398} | Moisture analyzer: Status |
| {399} | Moisture analyzer: Drying time and result |
| {400} | Moisture analyzer: Humidity content |
| {401} | Moisture analyzer: Dry mass content |
| {402} | Moisture analyzer: Humid/Dry |

CAUTION!

- 1) {0} and {1} variables format terminates with **CR LF** charcters, with this the newline occurs by default.

Every single printout can contain max 1900 characters (letters, numerals, non-standard characters, spaces). A user can apply non-standard characters depending on type of data that is to be printed out.

An example:

“RADWAG”

DATE: <current measurement date>

TIME: <current measurement time>

PRODUCT MASS: <current mass indication>

*****SIGNATURE:.....

<current working mode>

Enter printout content settings and design the printout using respective data variables and characters for text format.

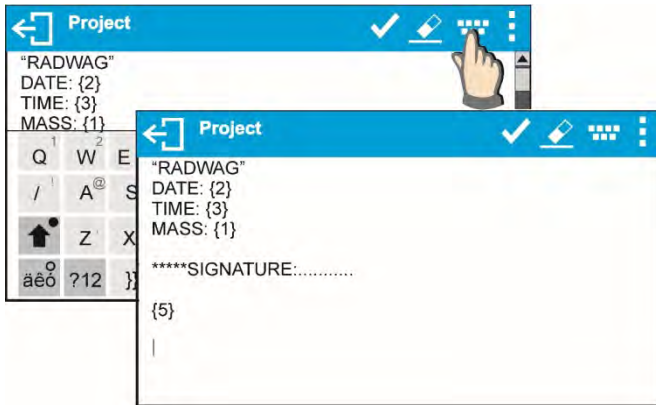

If you want to carry out HEADER or GLP or FOOTER printout using EPSON printer (equipped with autocutter blade) and crop the paper beneath the respective printout, then you have to select an option of non-standard printout comprising {151} variable, and set this option in header, GLP printout or footer settings, respectively (*means for entering control codes are described in section 21 of this user manual*).

In such case <SUFFIX> command should stay empty. Paper must be cropped underneath the FOOTER.

Exemplary settings:

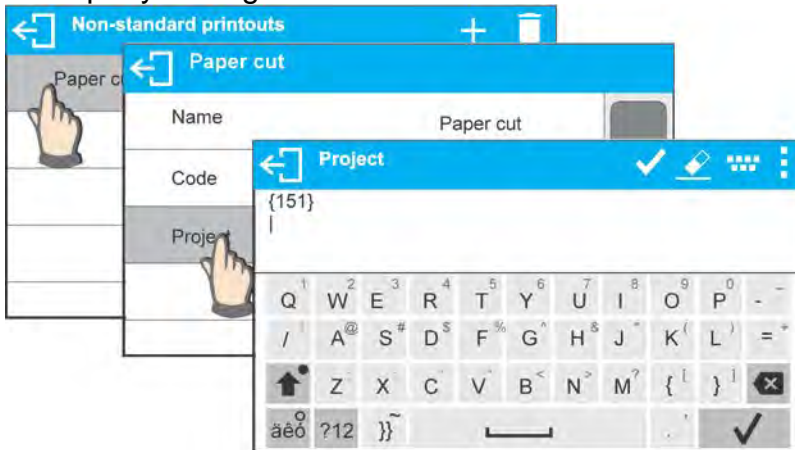

Means for inserting texts

- by an on-screen keyboard
- by a computer keyboard of USB type

A computer keyboard of USB type can be connected to a balance, this enables easier and quicker editing of the printouts.

Willing to insert any text, it is necessary to select a respective menu option and, using the keyboard, type the text.



12.5. Variables

Variable is defined as alphanumeric data which can be linked to printouts, products or other information related to weighing. Every variable is characterized by its content, the content must be given. Variables are used for entering various data during the weighing process, e.g. serial number or batch number. The program allows to enter 3 variables. Each can consist of max 31 characters.

In order to insert a variable content, you need to enter variable settings (VARIABLE 1, VARIABLE 2, VARIABLE 3) and enter the respective values using direction keys (arrows) on the balance keypad or a computer keyboard. Procedure for entering texts is the same as for non-standard printouts.

13. WORKING MODES – GENERAL INFORMATION

Standard version of X2 series balances feature the following working modes:

| | |
|---|---|
|  | <p>Weighing Means of operation: weight of a load is determined through an indirect measurement. A balance measures gravitational force which attracts the load. An obtained result is processed to a digital format and displayed in a form of measurement result.</p> |
|  | <p>Drying Means of operation: determining moisture content in a sample, obtained by vaporization of all moisture components from a sample placed inside a drying chamber of a moisture analyzer. A measurement result is automatically calculated by the software and visualized on an ongoing basis on moisture analyzer's display by comparing mass of a sample on measurement start, in progress, and at the end of drying process.</p> |

Particular working modes settings feature specific functions. The functions enable adapting mode operation to your individual needs. The special settings are activated on selecting a respective profile. A detailed description of specific functions is provided within description of working modes.

13.1. Working Modes Accessibility

Group of parameters enabling you to declare which functions are to be accessible. You can deactivate functions that are not used in course of balance operation, to do it, value **<NO>** has to be selected for a particular parameter.

Procedure:



13.2. Running Working Mode

To run working mode other than currently operated one:

- press pictogram of currently used working mode, the pictogram is located in the top left hand corner,

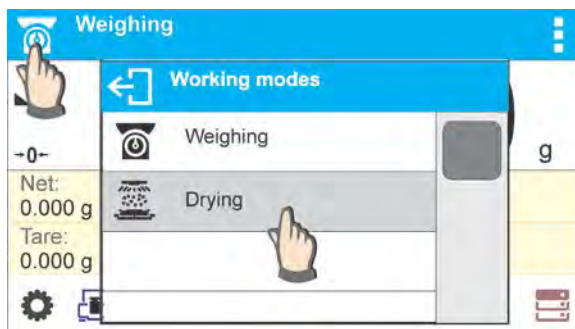

- wait for the available working modes list to be displayed,
- select the working mode you need to operate.

13.3. Parameters Related to a Working Mode

Each working mode has programmable parameters determining its functioning. Read point 9 of this user manual for description of possible settings for WEIGHING working mode. Settings for DRYING working mode are specified within its description.

14. DATABASES



Balance software features the following databases :

- Products (5 000 products)
- Users (100 users)
- Packaging (100 packaging types)
- Customers (1 000 customers)
- Drying modes (200 drying modes)
- Drying reports (5000 reports)
- Ambient Conditions (10 000 records)
- Weighings (50 000 records)

CAUTION!

It is not possible to edit some of the databases for a balance cooperating with E2R software. Shall you introduce any modifications on databases, use the PC software.

14.1. Database Connected Operations

The program enables the user with appropriate access level to carry out the following operations: adding new record, exporting data from databases, importing data to databases, deleting one record from the database, deleting all records from database, printing data saved in a record.

ADD NEW RECORD

Procedure:

1. Enter a database and press **+** (Add) button located in the top bar.
2. Define fields for the new record (data content depends on the database).
3. On returning to the databases window a new record is displayed on the list.

EXPORT

Procedure:

1. Insert USB flash drive.
2. Open the database that is to be exported.
3. Press  icon located in the top bar.

- The program automatically saves exported data to a pendrive file, respective prompts are displayed for confirmation of successfully completed operation.
- The name of a file depends on the database.

| Database | File name and extension |
|------------------------|--------------------------------|
| Operators database | users.x2 |
| Products database | products.x2 |
| Packaging database | packaging.x2 |
| Customers database | customers.x2 |
| Drying modes database | programs.x2 |
| Non-standard printouts | non_standard_printouts.x2 |

IMPORT

Procedure:

- Save the file with database content that is to be imported to a flash drive. Only files exported from other balance that have proper names and extensions can be imported – see table above.
- Insert USB flash drive.
- Enter database that is to be imported.
- Press  icon located in the top bar.
- The program automatically reads the file and the data is imported to the balance. Respective prompts are displayed for confirmation of successfully completed operation.



DELETE A RECORD

Procedure:

- Press the record and hold it.
- A message: <Confirm to delete> is displayed.
- Press  to confirm, the record is deleted from the list.

DELETE A DATABASE

Procedure:

- Enter selected database and press  (Delete everything) pictogram located in the top bar.
- A message: <Confirm to delete all records> is displayed.
- Press  to confirm, the database is deleted.

DRYING REPORTS and WEIGHING REPORTS cannot be imported. DRYING REPORTS database cannot be deleted. The databases content can only be exported and saved to a flash drive. Names of files with exported data consist of serial number and proper extension (see table below).

| Database | File name and extension |
|------------------|--------------------------------|
| Drying Reports | 123456.for |
| Weighing Reports | 123456.wei |

Files can be read using ALIBI Reader by RADWAG that can be downloaded from the website: www.radwag.pl.

AMBIENT CONDITIONS database serves informative purposes only. Using records preview option you can check ambient conditions and observe how they changed over time. The data saved to records can be printed by pressing  pictogram located in the top bar. Records' names contain date and time of saving the record's data to balance memory.

14.2. Products

Product database stores names of all products that can be weighed, counted, controlled.

List of parameters defined for a product:

1. Name [product code]
2. Code [EAN code for a product]
3. EAN [nominal mass/single product mass]
4. Mass [nominal mass/single product mass]
5. Tare [tare value, set automatically when the product is selected out of the database]
6. Min [low limit for product weighing in CHECKWEIGHING mode]
7. Max [high limit for product weighing in CHECKWEIGHING mode]
8. Tolerance [% value calculated in relation to mass, the parameter determines measuring area for which the measurement is recognized as correct for DOSING mode.]

CAUTION!

Remember to assign product to particular mode, as some of data values are adopted to the particular mode functions, e.g. mass in <Percent Weighing> mode is accepted as reference mass, whereas mass in <Parts Counting> mode is accepted as single part mass. When a particular product is used for different modes then its weight, taken from product data, is associated with different data for these modes.

14.3. Users

Users database features list of operators permissioned to operate the balance.

List of parameters defined for a user:

1. Name
2. Code
3. Password
4. Permissions level
5. Language

14.4. Packaging

List of used packaging with parameters such as name, code and weight value specified. When carrying out weighing process, upon selection of particular packaging, a respective tare value is operated automatically. The tare value is displayed with minus sign.

List of parameters defined for packaging:

1. Name
2. Code [internal code providing packaging identification]
3. Tare [packaging weight]

14.5. Customers

Customers database features a list of names of customers for whom the measurements are carried out.

List of parameters defined for a customer:

1. Name
2. Code [internal code providing customer identification]

3. NIP
4. Address
5. Postal code
6. City

14.6. Drying Program

Database of drying programs contains saved data on drying parameters which are activated to dry a product.

List of parameters defined for drying mode:

1. Name
2. Code
3. Drying profile
4. Finish mode
5. Printouts
6. Sample mass control

14.7. Drying Process Reports

Reports on drying process database stores information on carried out drying processes. Each report can be previewed and printed.

Procedure:

1. Enter  Databases> submenu, press <Drying Process Reports> key,
2. Select particular report button out of the list, use scroll buttons to find the report you need,
3. Report's name consists of date and time of its creation, e.g.: 2011.10.12 15:12:15.

Information provided by the Drying Process Report:

1. User
2. Drying mode
3. Start date
4. End date
5. Drying time
6. Status
7. End mass
8. Drying status
9. Indication

14.8. Ambient Conditions

Ambient Conditions database comprises ambient conditions related information. Depending on the setup, the ambient conditions record may comprise data such as temperature, humidity, atmospheric pressure. When the THB module is connected to the balance then its indications are recorded to the database too.

Procedure:

1. Enter  Databases> submenu, press <Ambient conditions> key.
2. Press the required record, if not visible scroll the records list down.

3. Record name comprises date and time.

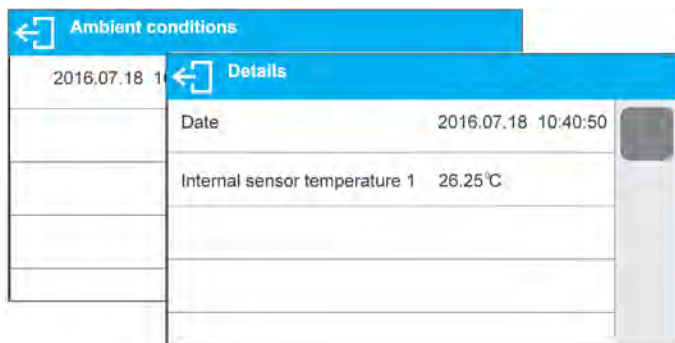

The screenshot shows a mobile application interface. At the top, there is a blue header bar with a back arrow icon and the text "Ambient conditions". Below this, there is a list of records. The first record is selected, and its details are shown in a separate window. The details window has a blue header bar with a back arrow icon and the text "Details". The details are as follows:

| Date | 2016.07.18 10:40:50 |
|-------------------------------|---------------------|
| Internal sensor temperature 1 | 26.25°C |

CAUTION!

The software saves ambient conditions record in a so called loop, i.e. when the measurement 10 001 is saved, the measurement 1 is automatically deleted from the balance's memory. **Records saved to balance memory cannot be deleted.**

14.9. Weighing Records

Each measurement result sent from a balance to a printer or a computer is saved in the database of weighing records. Balance user can preview data from each weighing record.

Procedure:

1. Enter  Databases> submenu.
2. Enter <Weighing records> database and press selected record.

Information defined for a weighing record:

- Measurement date
- Measurement time
- Measurement result
- Weight
- Tare value
- User
- Product name
- Customer, Customer name
- Packaging, tare name applied during product measurement
- Working mode name
- Variable 1
- Variable 2
- Variable 3

15. SAMPLE PREPARATION FOR DRYING

This section of the MA X2 user manual contains data on setting optimum test results during drying processes. There are hints for selection of appropriate drying parameters for various materials and substances.

15.1. Means of Moisture Content Measurement on a Moisture Analyzer

Measurement of moisture content in a tested sample is carried out by determining loss of mass in a sample by its heating (humidity evaporation).

RADWAG moisture analyzer MA X2 series comprises two components: a precision balance and a drying chamber. Compared to standard moisture content determining methods, the measurements with application of RADWAG moisture analyzer is much quicker and does not require additional mathematical calculations (a result of moisture content is previewed on an ongoing basis during product testing process).

Independently on moisture content determining method, the measurement accuracy is highly influenced by means of sample preparation and selection of testing parameters, such as:

- Sample size
- Sample type
- Drying temperature
- Drying time

In practice, the measurement accuracy is not as important as the speed of obtaining measurement result (control over technological process). Thus, heating a sample (with application of a halogen filament) carried out by a moisture analyzer, makes the measurement process very time efficient and short. Measurement speed can be additionally increased by appropriate adjusting moisture analyzer's parameters depending on tested substances.

Optimum temperature and drying time depend on sample type and size, and anticipated measuring accuracy. Selection of drying parameters can only be carried out on basis of test measurements.

15.2. Sampling and Preparation

Sample features, its preparation and size are very important factors influencing the speed and accuracy of measurement process.

Means of sampling and preparation are extremely important for repeatability of measurement results, as a sample should be a representative part of tested substance.

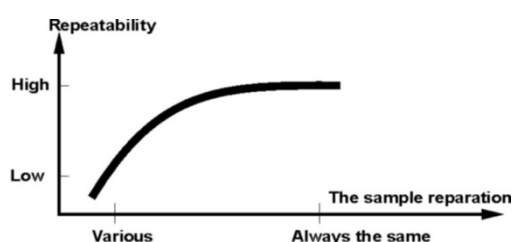

Final measurement result is vastly conditioned by precise and considered sample preparation. A sample used for analysis has to represent the total structure of tested material. Sampling process should determine: sampling means, sample disintegrating, particle size after disintegration, sample uniformity and other. The sampling process should

be carried out as quickly as possible, so that a sample does not lose or absorb humidity from surrounding area.

Applied sampling standards should match individual user needs and requirements of tested material, its consistence and sample size.

Number of samples

Increasing number of tested samples also increases statistic measurement certainty. Number of samples depends on uniformity of tested material, its purity, accuracy of applied measuring method and anticipated accuracy of obtained results.

Material mechanical disintegrating for measurements

Applied disintegrating method should be selected appropriately to tested material. Substances that are hard and brittle (crisp) can be disintegrated by cutting. Grinding such substances may cause their heating and thus humidity vaporization, resulting in unreliable measurement results. Unless a substance can be prepared for measurement otherwise than grinding, any possible moisture content loss should be calculated.

Use of high-silica sand

Ensuring optimum substance drying requires that a sample has the largest possible surface for moisture content evaporation. Test results of moisture content for substance with surface in a form of a shell (e.g. glucose syrup) or doughy (e.g. butter), can be much more reliable if a sample is mixed with a dried high-silica sand (improvement of measurement accuracy and repeatability). While using mixture, disposable weighing pan with extended brim must be applied (greater volume of a sample).

Grease in a form of paste or melting substances

Such substance requires testing with use of a filter made of glass fibre, which considerably increases active evaporation surface by separating the substance between the fibre. Initial filter drying is necessary only in case of measurements which require very high accuracy.

Liquid substances

It refers to liquid substances, which by creation of drops on their surface, caused by surface tension, may render difficulties in drying process. In such cases, it is proved to use a glass fibre filter to shorten measurement time. The filter causes separating tested liquid around the fibres, and increasing active evaporating surface. Initial filter drying is necessary only in case of measurements which require very high accuracy.

Substances with structure of leather or temperature sensitive

In case of such substances it is proved to use a glass fibre filter. While testing, a substance is placed on a drying pan, and sample surface is covered with a filter, which protects the sample from direct heat radiation. In such case, the sample is heated by convection (which is milder than radiation).

Substances containing sugar

The surface of such substances often may caramelize during testing procedure. Therefore, it is recommended to use thin layer of a sample, and moderate drying temperature.

Sample distribution on a pan:

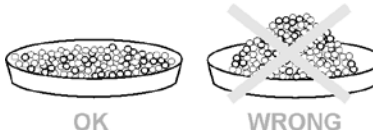
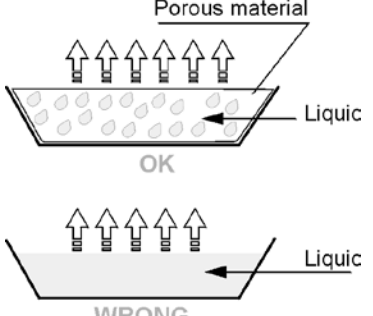
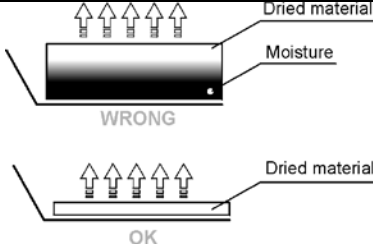
| | |
|--|---|
| <p>Loose materials Dried in their natural state, i.e. in their natural form or disintegrated. Sample disintegration causes smaller dispersion between the following measurements. Sample mass should not be too high, and the sample should be evenly spread on whole surface of the drying pan.</p> | <p style="text-align: center;">SAMPLE PREPARATION</p>  |
| <p>Liquid substances Semi-fluid substances are dried in their natural form. Large amount of grease (fat) occurring in some of substances makes moisture content determination difficult. In such case it is recommended to use additional components, which increase sample's active surface and aid moisture content releasing process from a sample. Such components are high silica sand, blotting paper or filter. Before drying a tested substance, initially dry the additional component, so that its humidity is close to zero.</p> |  |
| <p>Solid objects Depending on solid object's structure (dense or loose), moisture content determining process may take short or long time. The size of solid's surface determines the speed of drying process, and measurement reliability. Thus, the surface of a solid object should be as large as possible. Since solid objects release moisture through their outer surface, sample thickness is another important factor.</p> |  |

16. SELECTION OF DRYING PARAMETERS

16.1. Selecting Optimum Mass for a Sample

Sample mass influences the accuracy of measurement result and measurement time. Higher mass of a sample, causes higher amount of water (moisture content) which needs to evaporate, and therefore measurement time is also longer.

Obtaining short measurement time is feasible in case of small sample mass, but sample mass cannot be too small, as it may negatively influence required measurement accuracy.

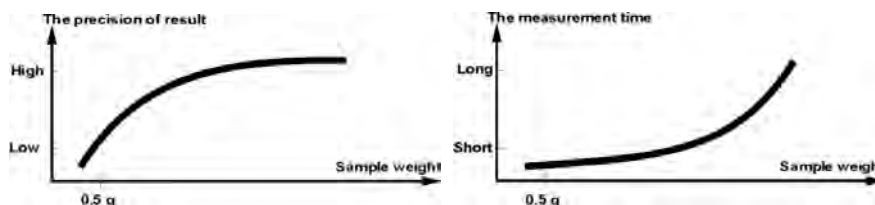

16.2. Influence of Sample Weight on Measurement Result Repeatability

Sample mass considerably influences repeatability of measurement results obtained on a moisture analyzer. Relation between sample mass and repeatability is presented in a table below.

| Sample weight | Repeatability |
|---------------|---------------|
| ~ 2g | ±0.05% |
| ~ 10g | ±0.01% |

The above data refers to a model, uniform sample, containing no moisture due to the evaporation process and showing no signs of decomposition (e.g. wet high-silica sand).

The results uncertainty cannot be avoided, this is due to sample nature and moisture analyzer repeatability. In practice, it means that obtained measurement result may exceed repeatability values provided above.

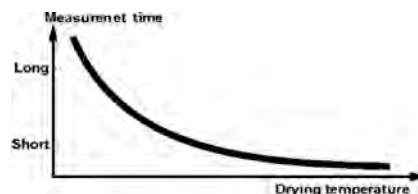

16.3. Drying Temperature

Drying temperature has the largest impact on drying time. Temperature value depends on type of dried substance. Too low drying temperature causes too low moisture content evaporation (under-dried sample), and consequently unnecessary extending of measurement time. Too high drying temperature causes burning of dried sample (sample overheating, chemical decomposition). Drying temperature of traditional method (using a furnace) is specified in applicable industry or company standards. Unless standards apply, then temperature should be adjusted by tests.

On selecting drying temperature value, proceed as follows:

- Determine moisture content in a sample
- Determine temperature of substance chemical decomposition by tests
- Compare result obtained on a moisture analyzer with the one of traditional method

When drying a sample with high moisture content, it is possible to shorten measurement time by selecting quick or step drying mode. In such case, the majority of moisture content is released drying temperature higher than set. Only after some time, the temperature is lowered to the set value, and maintained until completing drying process.

16.4. Selecting Drying Profile

The software of moisture analyzer enables selecting one of four drying profiles:

- Standard
- Quick
- Mild
- Step

STANDARD profile

Standard profile is the most frequently used of all drying profiles. It enables accurate determining of moisture content in a dried sample.

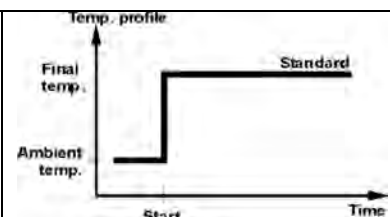

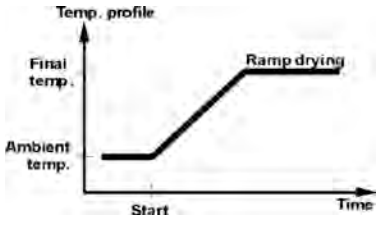
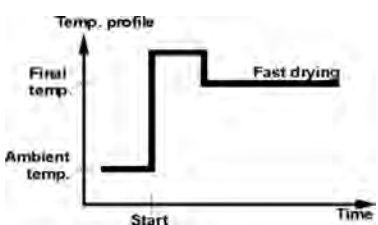
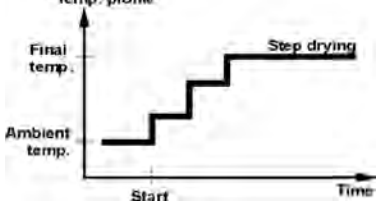
| | |
|---|---|
| <p>MILD profile Mild profile is used in case of drying substances that are sensitive to rapid heat emitted by filaments operating at full power in the initial stage of drying process. This profile prevents from decomposing of substances sensitive to heat by mild temperature increase in set amount of time (time interval has to be selected by tests). Mild profile is recommended to drying samples of leather structure.</p> |  |
| <p>FAST profile Fast profile is recommended to drying samples that moisture content varies from 5%, and 15%. In the initial stage of Fast profile, heating takes place at full power of the filaments, causing heating the drying chamber to increased temperature (maximum temperature value is higher by 30% from set drying temperature). Overheating compensates heat loss during evaporation of large moisture content in the test's initial stage.</p> |  |
| <p>STEP profile Enables determining up to three steps with random drying temperature. Step profile is recommended for drying substances with moisture content over 15%. Temperature and heating time in each step have to be adjusted by tests.</p> |  |

16.5. Drying Time

Drying time is set by selecting one of available finish mode criteria. This means that a moisture analyzer must meet pre-set criterion (one of the requirements: mass over time, time) to automatically finish the drying process.

Finish of drying process can be triggered by amount of time, independently on loss in mass. This criterion is used for substances that may decompose during drying process, and their mass does not reach constant value.

The second criterion is loss in mass (less than 1 mg) in defined amount of time.

Automatic finish mode (Auto switch off mode)

The operator can choose between various types of finish modes:

- Automatic 1 (change 1mg/10s)
- Automatic 2 (change 1mg/25s)
- Automatic 3 (change 1mg/60s)
- Automatic 4 (change 1mg/90s)
- Automatic 5 (change 1mg/120s)

Time-defined finish mode - drying process finish takes place on elapsing a set amount of time, independently on measurement result (maximum drying time 99 hours 59 minutes).

Manual finish mode - the operator ends drying process manually by pressing START/STOP soft key on moisture analyzer's display.

Defined finish mode – user defined criterion. The operator determines the limit value for loss of mass and time in which the loss of mass must not exceed a pre-set value. As the moisture analyzer reaches the set criterion it automatically finishes the measurement (drying process).

- User defined 1 (Δm – change of mass and Δt – change of time must be given, the former in mg, the later amounts to 120 s. maximally)

- User defined 2 (set moisture content change ratio $\Delta\%M$ over time 60s)

16.6. Drying Profile Analysis

For the first case, the drying profile is an asymptote. Moisture content value remains constant even after long drying time. Using this drying profile makes determination of humidity easy. The measurement result is always referred to constant value of asymptote. The result corresponds easily and it is not difficult to select a proper criterion of finish mode.

For the second case the drying process is quick at the beginning, next it stabilizes. Moisture content value is never constant. Drying process profile may proceed as follows:

The sample undergoes thermal decomposition, wherein evaporation takes place and as a result the product weigh decreases. Evaporation of grease, oil, plastic or other volatile materials may take much more time than in case of water. Difficult to evaporate materials drop weight.

Result obtained using this mode may be optimistic:

- Lower temperature may slower material reaction.
- Selection of appropriate criterion may let the user recognize end of analysis, within described drying step.
- Constant drying often assures good drying results.
- Maintaining start sample weight permanently (+10%....+20%).

17. DRYING PROCESS PERFORMED BY MEANS OF QUICK MENU

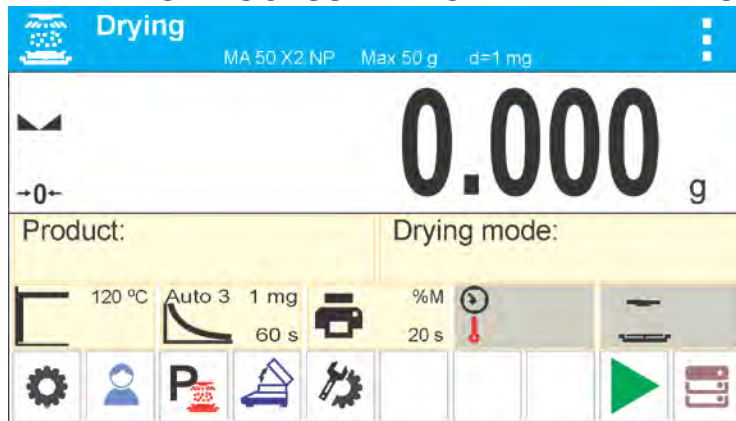

Default display configuration in drying mode.

Current drying parameters are displayed in a form of pictograms in the middle of the information field. Willing to perform the procedure in accordance with other parameters, enter the settings and modify the respective parameters values.

Enter drying process menu, set the following parameters:

- Drying process mode and drying process parameters,
- Drying process finish mode and finish mode parameters
- Unit for a displayed and printed result
- Interval for measurement printout, wherein the measurements are printed during the drying process

17.1. Drying Process Profile and Drying Parameters



Enter drying parameters settings and select mode type. Upon selection fields enabling setting profile parameters are displayed. Parameters depend on selected mode.

Drying process mode parameter takes the following values:

- **STANDARD drying profile** – For standard profile set drying temperature in which a sample is to be tested.
- **FAST drying profile** - For quick profile, set both, heating time in a temperature higher than the preset one and temperature for which a sample is to be tested.

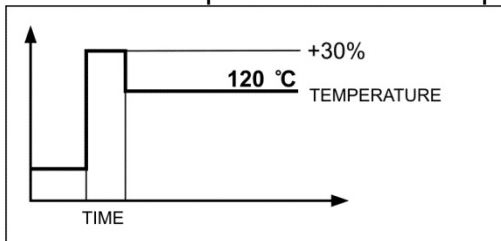

Specific feature of this drying profile is fast increase of drying temperature in short period of time. When compared to the preset temperature, the drying temperature rises 30% within 180 seconds and it is maintained at this level for a specified amount of time, next it drops to temperature value preset in drying profile parameters.

CAUTION!

For **Fast** profile set the drying temperature and heating time 30% higher than set temperature. Heating time is measured since reaching the set temperature.

- **MILD drying profile** - For mild profile, set length of time within which moisture analyzer is to reach specified temperature and temperature for which a sample is to be tested.

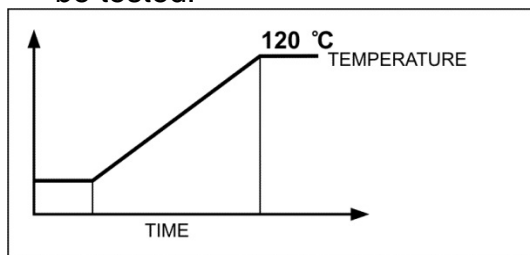

- **STEP drying profile** - For step profile, set heating time in temperature number one, first step temperature, heating time in temperature number two, second step temperature and temperature in which a sample is to be tested.

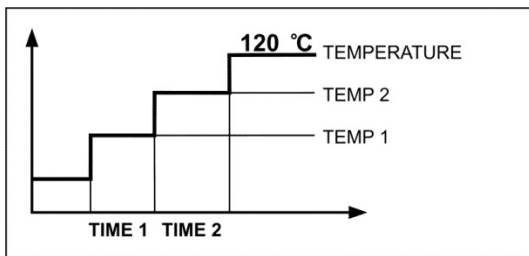

CAUTION!

For **Step** profile, set step temperature „1” and „2” and temperature of drying, set also time heating time in particular indirect temperatures (1 and 2). Time for heating in particular steps is counted from the moment of reaching a preset temperature for a particular step.

17.2. Automatic Finish Mode

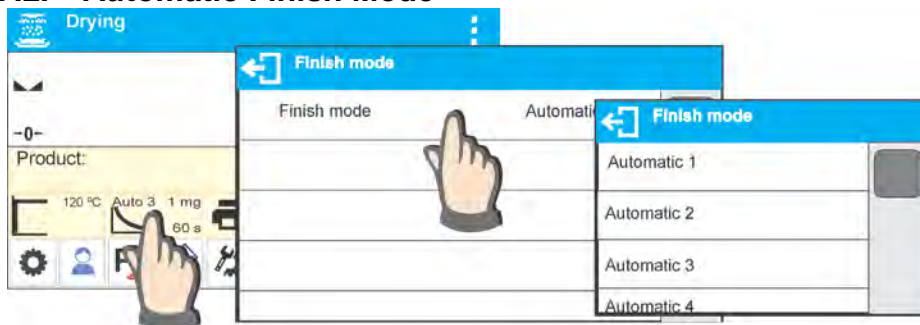

Automatic finish mode (Auto switch off mode) takes the following values:

- Automatic 1** - auto switch-off (mass change of 1mg / within time length of 10s)
- Automatic 2** - auto switch-off (mass change of 1mg / within time length of 25s)
- Automatic 3** - auto switch-off (mass change of 1mg / within time length of 60s)
- Automatic 4** - auto switch-off (mass change of 1mg / within time length of 90s)
- Automatic 5** - auto switch-off (mass change of 1mg / within time length of 120s)
- Manual** - Manual switch-off (on pressing **Start/Stop** button, maximum drying time is 99 hours and 59 minutes, when drying takes this long or longer the drying process is finished automatically)
- Time-defined**- time-defined switch-off (maximum drying time is 99 hours 59 minutes)
- Defined 1** - defined switch-off (*change of mass comprised within the balance range, set with moisture analyzer readability, time interval ranging from 1 to 120s*)
- Defined 2** – defined switch-off (*change in humidity set with moisture analyzer readability, time interval ranging from 1 to 60s*).

17.3. Unit of Displayed and Printed Measurement

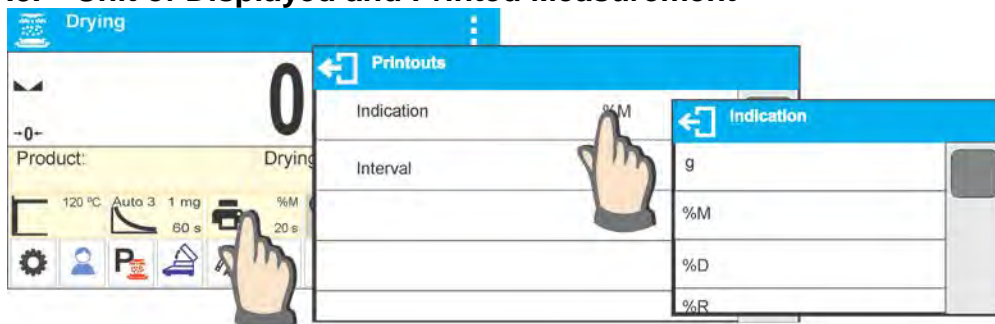

- g** - mass change, measurement result is mass change recorded during drying process,
- %M** - percent loss of weight, displays weight change recorded during drying process expressed in percent,
- %D** - part of dry mass obtained during drying process, expressed in percent, measurement result is part of mass that is remaining on a drying pan after humidity content evaporation,
- %R** - humid / dry ratio obtained as a result of drying process, expressed in percent, measurement result is part of mass that evaporated from the dried sample during drying process,

17.4. Printout interval

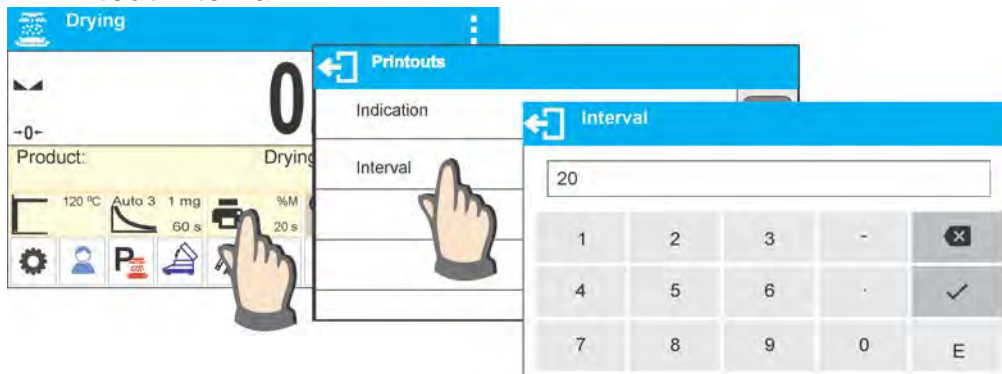

The time interval between printouts in seconds ranging from 0 to 120.

18. DRYING PROCESS PERFORMED WITH USE OF DRYING MODES DATABASE

Moisture analyzer can record up to 200 drying modes that may be freely configured, recorded and used.

Procedure – selecting a mode:

1. Insert the mode to moisture analyzer's memory (read section 14 *Databases*)
2. Select inserted mode prior drying process. Drying parameters update to parameters saved in selected drying mode.

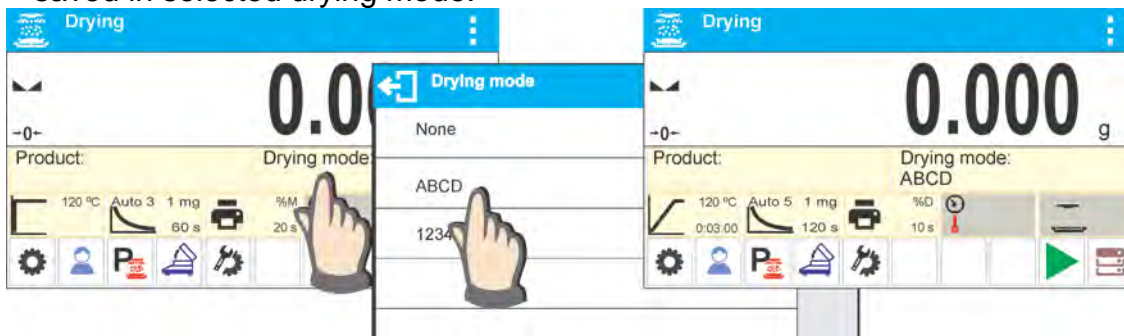



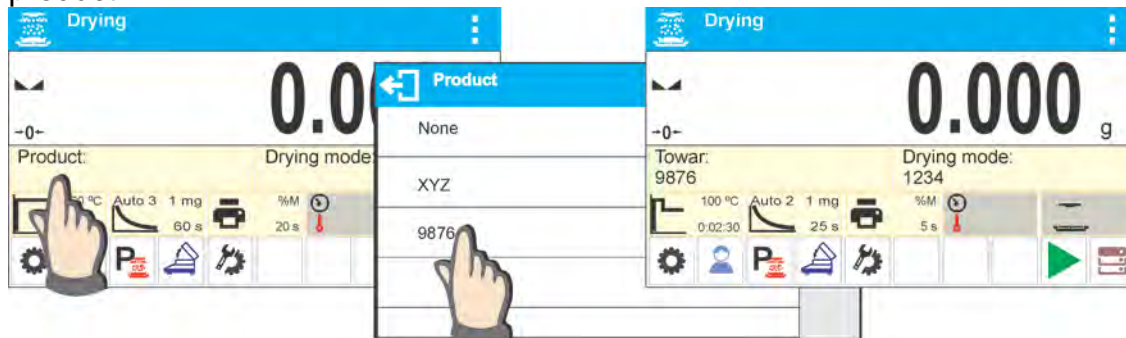

Or:

3. Insert data related to product/sample that is to be dried. Set the inserted mode as drying mode (read section 14 *Databases*).
4. Select inserted product as a current one prior drying process. Drying parameters update to parameters saved in the drying mode that is assigned to a selected product.

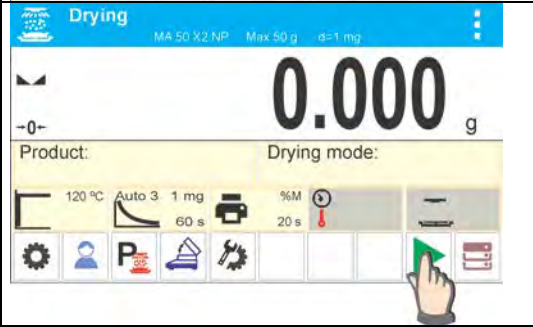

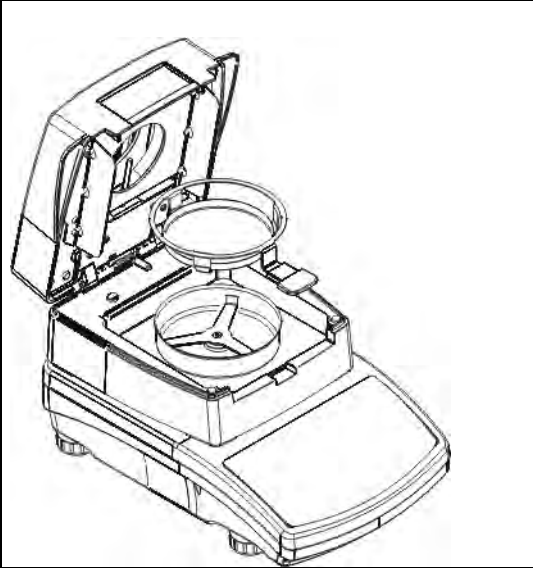
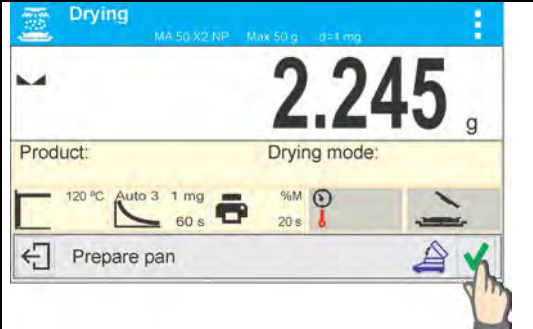
19. DRYING PROCESS

| | |
|---|--|
|  | <p>Drying process settings are displayed in the information field above the buttons.</p> |
|  | <p>Press Start button in order to run the drying process. Prompts and messages are displayed making moisture analyzer operation easier. Follow the prompts to correctly prepare the sample and to perform the process of humidity content determination for a tested sample.</p> |
|  | <p>Program prompts you to prepare a weighing pan. A respective pictogram on drying chamber status is displayed.</p> |
|  | <p>Place the disposable weighing pan in a pan handle and deposit it on a bracket. The display shows disposable pan weight.</p> <p>It is recommended to close the drying chamber in order to provide stable ambient conditions while taring.</p> |
|  | <p>Press  key to zero the weighing pan weight.</p> |

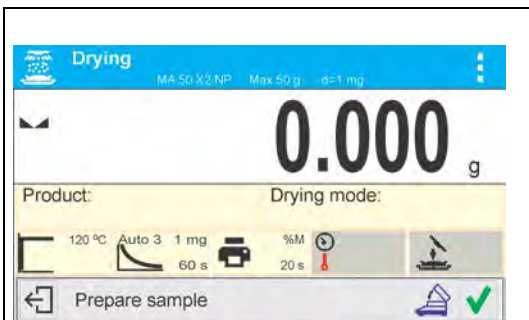

Indication equals ZERO, subsequent prompt is displayed and the pictogram on drying chamber status changes.

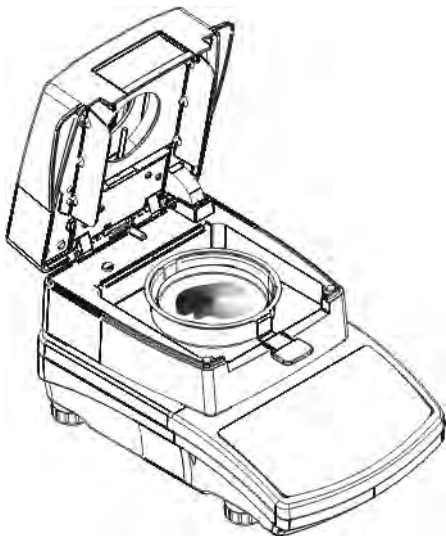

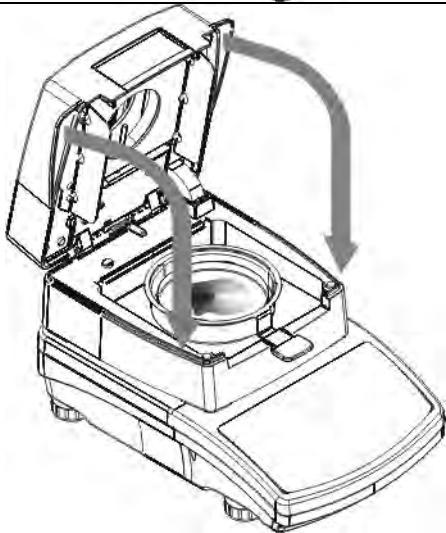

Deposit sample on a weighing pan.
Sample weight shall be selected on the basis of prior experience and tested material characteristics.



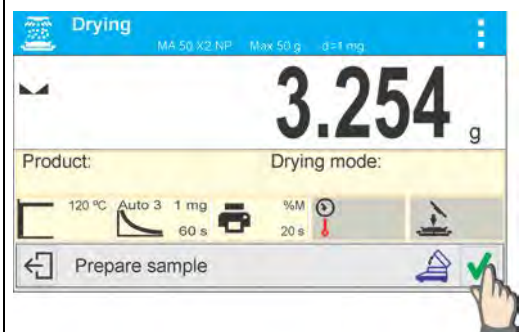

On sample preparation and result stabilization close the drying chamber and confirm the operation by pressing  key. Drying process starts automatically.



| | |
|--|--|
| | <p>Information on the drying process is displayed, moisture analyzer proceeds to carrying it out accordingly to set parameters. Required mass measurements and calculations of tested sample moisture content are performed, wherein the calculations are a result of mass change. On process start, printout header is sent to a selected interface (accordingly to set printout options – parameter group DRYING PROCESS REPORT/HEADER).</p> |
| | <p>In course of a drying process current weight results and information on the process is displayed (test duration, drying chamber temperature, etc.). In course of a drying process (accordingly to set printout options – parameter group DRYING PROCESS REPORT/MEASUREMENT) measurements are sent to a selected communication port in a preset time intervals (INTERVAL).</p> |
| | <p> key allows you to swap between displayed result type during the process.</p> |
| | <p>Upon drying process completion, summary of the test is displayed, final humidity result is held. Printout footer is sent to a selected interface (accordingly to set printout options – parameter group DRYING PROCESS REPORT/FOOTER).</p> |

Drying process may be aborted at any time. In order to abort the process, press  key and confirm completion by pressing  key.

Manual auto switch-off mode is an exception to the rule – for moisture analyzer working in this mode, the drying process ends upon pressing  key, there is no need to confirm completion by pressing  key.

Report on drying is printed again by pressing  key located in the bottom bar of the display.

Report is also automatically saved in moisture analyzer's memory in the drying reports database.

In order to return to the main screen of drying process settings press  key located in the bottom bar of the display. Moisture analyzer returns to its initial state, completed process summary is blanked. The moisture analyzer is ready to perform another test.

An example of drying report:

```

-----Drying process report-----
Start date          2015.07.08
Start time          12:28:13
Balance type       MAX2 NH
Balance Id         123456
User               AAAAAA
Product            xxxxxxxx
Drying mode        ABCD
-----Drying process parameters-----
Drying profile     Standard
100 °C
Finish mode        Automatic 3
1 mg/60s
Indication         %M
Interval           10s
Start mass         0.459 g
-----
0:00:00            0.000 %M
0:00:10            0.583 %M
0:00:20            2.524 %M
0:00:30            4.272 %M
0:00:40            5.049 %M
0:00:50            5.631 %M
0:01:00            5.825 %M
0:01:10            5.825 %M
0:01:20            5.825 %M
0:01:30            5.631 %M
0:01:40            5.631 %M
0:01:43            5.437 %M
Status             Completed
End date           2016.07.08
End time           12:29:55
Drying time        0:01:42
End mass           0.487 g
Indication         5.437 %M

Signature
.....
    
```



Header
drying process report



Measurement
drying process report

Footer
drying process report

20. COMMUNICATION

COMMUNICATION menu is comprised within Parameters menu. It is accessed by pressing  key. The balance can communicate with a peripheral device, wherein the communication is established via the following ports:

- COM 1 (RS232),
- USB 1 type A,
- USB 2 type B,
- Ethernet,
- Wi-Fi.

The ports can be configured using <Communication> parameter group. To enter this submenu, press  key, next press “Communication” key.

20.1. RS 232 Ports Settings

Procedure:

1. Select communication port <COM1>.
2. Set appropriate values.

The RS 232 ports enable the following setting of transmission parameters:

- Baud rate - 2400, 4800, 9600, 19200, 38400, 57600, 115200 bit/s
- Parity - None, Even, Odd

20.2. ETHERNET Port Settings

Procedure:

Select <  Ethernet > communication port, next set appropriate values:

- DHCP - Yes – No
- IP Address - 192.168.0.2
- Subnet mask - 255.255.255.0
- Default gate - 192.168.0.1

CAUTION!

The above presented settings serve information purposes only. Transmission parameters should be selected in accordance with the settings of customer's local network.

Return to weighing mode and restart the device.

20.3. Wi-Fi Port Settings

CAUTION!

1. Make sure that transmission parameters are accordant for your local network settings,
2. For correct communication via Wi-Fi, set port parameter for computer to <WIFI> value: <PERIPHERALS/COMPUTER/PORT/WIFI>, next set the parameters as described below.

Balance equipped with Wi-Fi module features a respective pictogram at the home screen in the top right-hand corner:

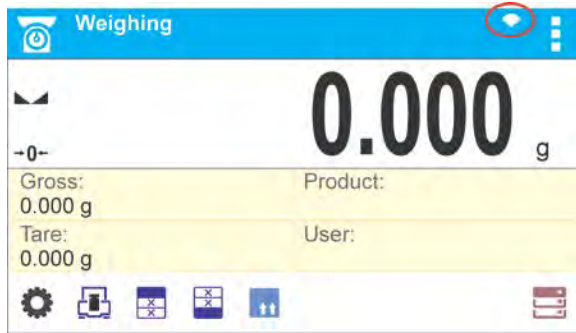

Pictogram for Wi-Fi network connection status:

| No. | Pictogram | Overview |
|-----|-----------|--|
| 1 | | Balance connected, very strong signal |
| 2 | | Balance connected, strong signal |
| 3 | | Balance connected, poor signal |
| 4 | | Balance connected, very poor signal |
| 5 | | No connection (too poor signal or inaccessible selected network or invalid connection parameters – password, IP, etc.) |

Exemplary settings for Wi-Fi port:

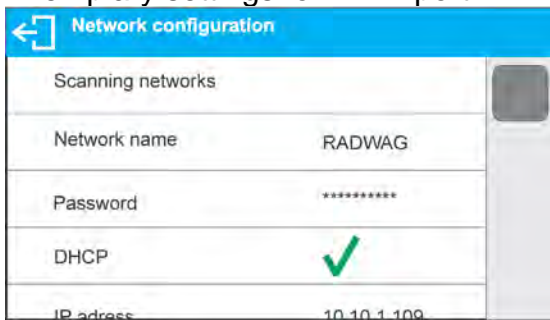

CAUTION!

The above presented settings serve information purposes only. Make sure that your transmission parameters are accordant for your local network settings.

Procedure:

1. Select <WIFI> communication port

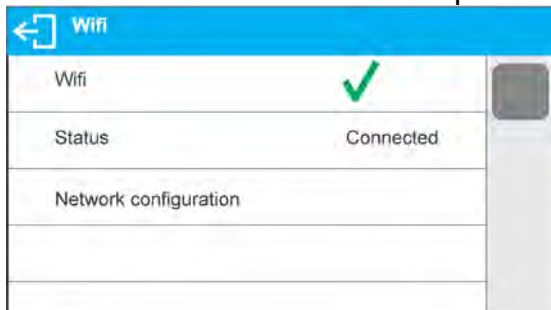

2. Enter <NETWORK CONFIGURATION> parameter and set DHCP parameter value:

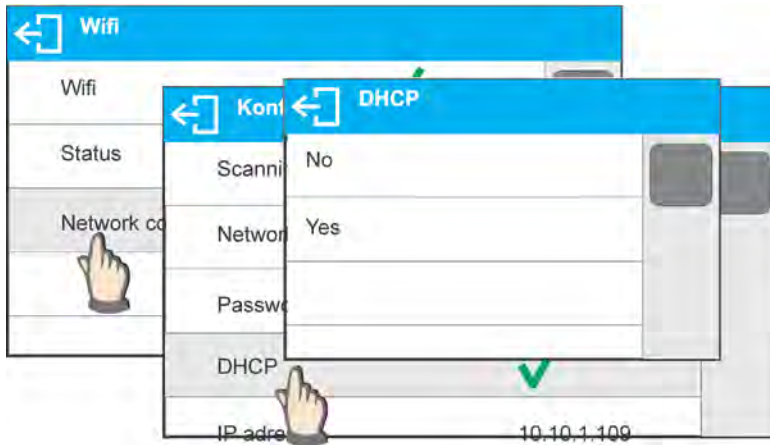

With DHCP set to NO value, enter manually: <IP>, <MASK>, <DEFAULT GATE> parameters.

With DHCP set to YES value, the balance software automatically reads and displays data assigned by Wi-Fi router by means of which the balance is to be connected,

3. Enter <SCANNING NETWORKS> parameter and start network searching procedure. Upon completion, list of detected networks is displayed along with information on signal strength and channel number.

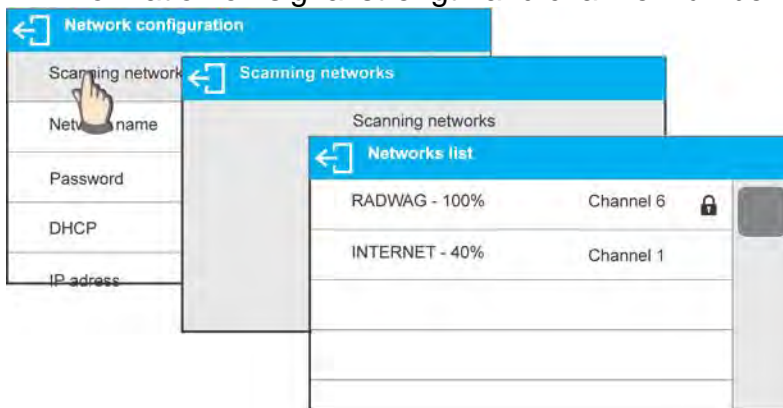

4. Select network of your choice.

5. Password window is displayed, enter the password using an on-screen keyboard.

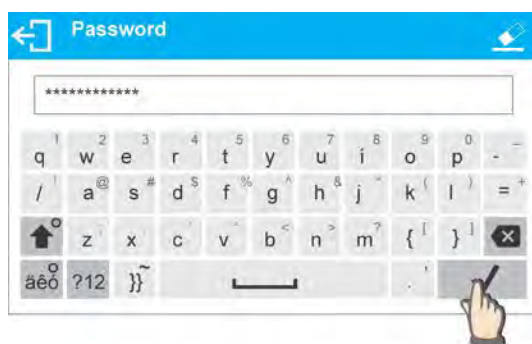

6. <NETWORK CONFIGURATION> window is displayed, connection procedure starts automatically.

7. Press  button to go one level up, <STATUS> parameter features <CONNECTING> sign informing on the fact that the balance tries to connect the network,

8. For successfully established connection <CONNECTING> status turns to <CONNECTED> status, respective pictogram is displayed (see pictogram overview above)

9. If it takes too long to establish connection it may be concluded that connection parameters are invalid (password etc.), check the parameters and try to reestablish connection.
10. If you fail to reestablish connection, contact RADWAG service.

The selected network and parameters for connection are stored in the balance program. The program connects to the network using the stored parameters each time the balance is activated.

To disconnect the network turn the communication off:

COMMUNICATION/WIFI/WIFI – NO



20.4. USB Ports

USB 1 port of type A is intended for:

- Connecting a USB flash drive storing <FAT files system>,
- Connecting balance to PCL printer,
- Connecting EPSON TM-T20 printer to USB port

USB flash drive may be used for printing data on measurements (setting PRINTER/PORT parameter to PENDRIVE value). Measurement data printout operation is described in section 21.3. of this user manual. Additionally, databases (*for description of this function go to section 14 of this user manual*) and user's parameters settings can be copied balance to balance. On inserting USB flash drive an Export/Import group of parameters opens automatically. If you are authorized you can:

Export: databases, user's parameters

Import: databases, user's parameters

During export the program saves files with databases and parameters content on a flash drive. The exported data can be imported to any X2 series balance.

Please remember that for PCL printer the drivers print completely filled page, i.e. the page will be printed only upon pressing PRINT button, located on a balance, for several times (it depends on a printout size how many times the PRINT button shall be pressed prior printout).

It is possible to obtain printout upon pressing PRINT button once only, supposing that control code <0C> has been set as SUFFIX (*for description of this function go to section 21.2 Printer*).

USB 2 port of type B is intended for:

- Connecting balance to a PC computer



In order to make connection of balance and computer possible, it is necessary to install virtual COM port in a computer.

To carry out this procedure, you need a respective driver installer which may be either downloaded from the website www.radwag.pl or taken from a CD with manuals: *R X2 SERIES RADWAG USB DRIVER x.x.x.exe*.

Procedure:

1. Run driver installer.

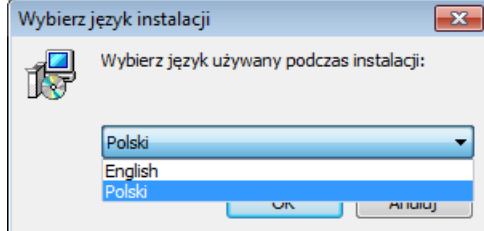
Startup dialog window:

| | |
|--|--|
|  | <p>Select language version.</p> |
|  | <p>In order to continue, press „Next” button.</p> |

Window for target folder selection:

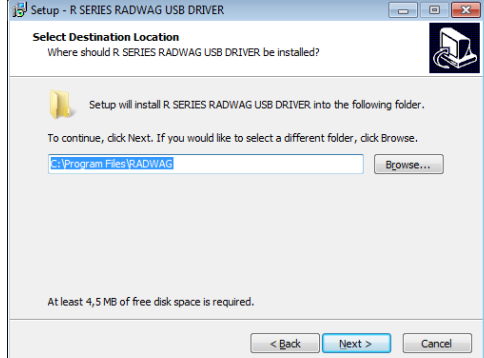
| | |
|---|---|
|  | <p>Select a respective folder and click „Next” key to proceed.</p> |
|---|---|

“Ready to Install” window:

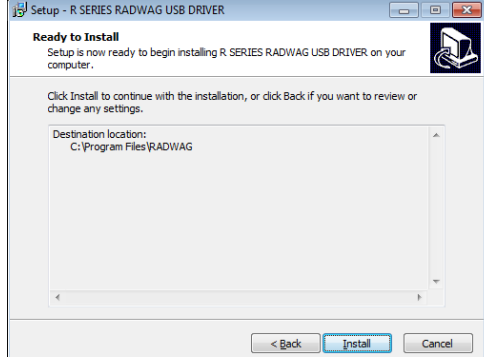
| | |
|---|---|
|  | <p>In order to run installation process, press „Install” key and clicking on respective keys, follow the install wizard.</p> |
|---|---|

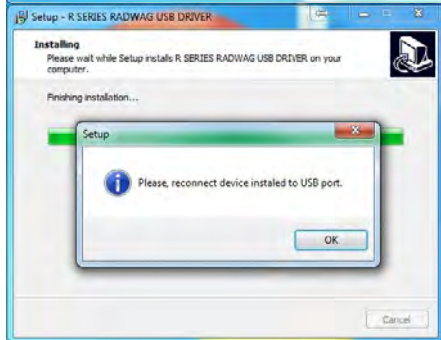
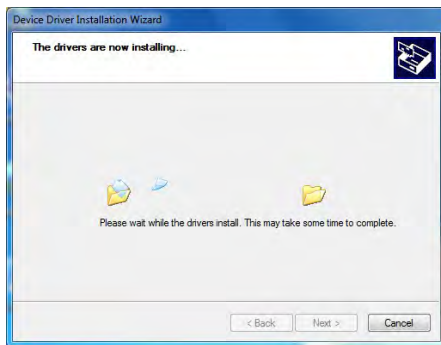

- Having completed driver installation, connect balance to a computer, use 1,8-meter long USB A/B cable maximally (in case of already connected balance, it is necessary to disconnect it and using USB cable connect the balance again).



3. The system detects the new USB device and automatically starts searching a respective driver.
4. Go to Device Manager and check number assigned to virtual COM port.

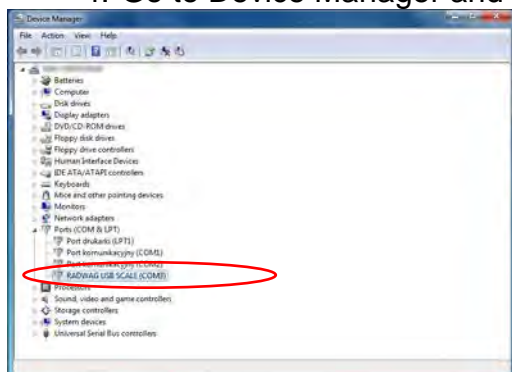

For this very case it is STMicroelectronics Virtual COM Port (COM8).

5. Set balance parameters: select USB value for parameter COMPUTER/PORT.
6. Run software for measurement readout.
7. Use the program to set parameters for communication – select respective COM port (for the very case it is COM8), i.e. the one which has been formed while installing drivers.
8. Start cooperation.

21. PERIPHERALS

PERIPHERALS menu is comprised within Parameters menu. It is accessed by pressing  key. The menu features list of devices that can cooperate with the balance.

21.1. Computer

Carry out configuration using <Computer> submenu.

Procedure:

1. Press  key, next press: <Peripherals / Computer>,
2. Set parameters related to cooperation with a computer:
 - computer port
 - available options: none, COM 1, USB, Ethernet, Wi-Fi, USB Free Link

CAUTION: In order to set USB Free Link instead of USB select any other port (e.g. none, COM1, etc.) and next select USB Free Link port. Analogously when changing USB Free Link to USB.

USB FREE LINK – USB type B port, to which the computer is connected. The tool, acting like a keyboard, is used for entering data for peripherals. On proper modification of non-standard printout and sending proper command from the computer or on pressing ENTER on balance's keyboard, the data from non-standard printout is directly entered to computer programs, e.g. Excel, Word, Notepad etc.

Press <USB FREE LINK> and configure port settings to enable balance correct cooperation with computer programs:

SPREAD SHEET – value YES - cooperation with Excel type program,
– value NO – cooperation with other programs,

DELAY – if any 'looses' of transferred information occur (caused by data auto-entering or auto-formatting by computer program) during cooperation with Excel type program, parameter value should be set to <2>. If the 'looses' still occur, parameter value should be higher. The user can change parameter's value ranging from 0 (quick data transfer) to 9 (slow data transfer – around 10 characters per second).

For Free Link printout option set (keyboard emulator) all languages without special characters are operated by means of 'QWERTY' keyboard.

Additionally, the following languages are operated:

- Polish for 'Polish (Programmers) keyboard'. In printer options located in the balance select Windows-1250 code page (Central European, Latin-2). The following Polish diacritical signs are added: ą, ć, ę, ł, ń, ó, ś, ź, ż.
- German for 'Germany (German) keyboard'. In printer options located in the balance select Windows -1252 code page (Western European, Latin-1). The following German diacritical signs are added: ä, ö, ü, ß. The keyboard layout changes to 'QWERTZ'. The characteristic feature of such keyboard is 'ß' sign located on the right side of 'zero' sign.

Caution! Free Link printout option enables use of signs available exclusively on the keyboard. Key combination (pressing letter and 'Shift' button at the same time) allows writing capital letters and special characters. Polish and German were completed with

basic special characters written using key combination of a letter and right 'Alt' button. Other special characters are not operated in Free Link printout option.

- port settings
 - settings related to a port selected for computer connection
CAUTION: for Ethernet and Wi-Fi port Timeout parameter is on. The parameter specifies time delay – time interval for disconnection, counted from the moment of the most recent command sent from the device to which the balance is connected. Timeout parameter value has to be entered in milliseconds [ms].

- E2R
 - options: Yes/No
E2R is a control system designed to monitor all weighing processes carried out on a balance, with E2R system activated some databases can be operated by computer exclusively (access to specified functions and options using balance is not possible).
To start cooperation with E2R system, set <E2R> parameter to <YES> value, as a result a respective pictogram is displayed in the top bar:

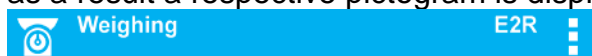

CAUTION: turn the continuous transmission off in order to provide correct cooperation with E2R system.

- address
 - parameter for setting address of balance connected with a computer
- weighing operation printout template
 - parameter enabling you to design customized printout, for this use window with printout template. For more information on designing printouts read section 11.2 of this user manual.
- continuous transmission, parameter enabling to turn on/off continuous transmission of a weighing result, available options:
 - continuous transmission in calibration unit, indications are transmitted in a main unit (calibration) independently from currently selected weight unit,
 - continuous transmission in current unit, indications are transmitted in a currently selected weight unit, the transmitted unit changes along with the current unit change (Units key),
 - continuous transmission turned off: <NONE>,

CAUTION!

Continuous transmission can be turned on/off by a respective message sent from a computer (read COMMUNICATION PROTOCOL).

- interval
Parameter enables setting frequency of printouts for continuous transmission. Frequency of printouts is set in seconds, wherein the accuracy is 0.1s. you may set any time value ranging from 1000 to 0.1 s.
The setting is valid for continuous transmission in calibration unit and in current unit activated by means of the balance, it is also valid for continuous transmission activated by command sent from a computer.

21.2. Printer

Submenu <Printer> enables you to select a port to which data is sent upon pressing  key on a balance keyboard. Content of sent data is set in <PRINTOUTS/GLP PRINTOUTS> parameter.

Procedure:

1. Press  key.
2. Enter <PERIPHERALS> menu.
3. Enter <PRINTER> menu.
 - o set balance parameters related to cooperation with the printer; i.e. <PORT> to

which a printer is to be connected upon pressing  button (printer connected), options:

CAUTION: *In order to set USB Free Link instead of USB select any other port (e.g. none, COM1, etc.) and next select USB Free Link port. Analogously when changing USB Free Link to USB.*

- **COM 1** – RS 232 port, the one to which a printer is connected
- **USB** – USB 1 port type A, the one to which a PCL printer or EPSON printer is connected
- **Ethernet** – port sending data to a dedicated RADWAG software, e.g. PW-WIN, operated on a computer connected to a balance via network.
- **PENDRIVE** – USB port type A for connecting USB flash drive. Set format of saved file. You can save the data in *.txt format (text file that can be opened on the computer using Notepad) or *.csv format (file that can be opened using Excel).
- **WIFI** – port intended to enable sending data to RADWAG manufactured software PW WIN (opened on computer connected to balance via Wi-Fi), to printer featuring Wi-Fi port or to network printer.
- **USB PC** – USB port type B, intended for connection of computer with RADWAG-invented PC software, e.g. PW-WIN.
- **USB FREE LINK** – USB type B port, to which the computer is connected. The tool, acting like a keyboard, is used for entering data for peripherals. On proper modification of non-standard printout and sending proper command from the computer or on pressing ENTER on balance's keyboard, the data from non-standard printout is directly entered to computer programs, e.g. Excel, Word, Notepad etc. Press <USB FREE LINK> and configure port settings to enable balance correct cooperation with computer programs:

SPREAD SHEET – value YES - cooperation with Excel type program,
– value NO – cooperation with other programs,

DELAY – if any 'looses' of transferred information occur (caused by data auto-entering or auto-formatting by computer program) during cooperation with Excel type program, parameter value should be set to <2>. If the 'looses' still occur, parameter value should be higher. The user can change parameter's value ranging from 0 (quick data transfer) to 9 (slow data transfer – around 10 characters per second).

On Free Link printout option set (keyboard emulator) all languages without special characters are operated by means of 'QWERTY' keyboard.

Additionally, the following languages are operated:

- Polish for 'Polish (Programmers) keyboard'. In printer options located in the balance select Windows-1250 code page (Central European, Latin-2). The following Polish diacritical signs are added: ą, ć, ę, ł, ń, ó, ś, ź, ż.
- German for 'Germany (German) keyboard'. In printer options located in the balance select Windows -1252 code page (Western European, Latin-1). The following German diacritical signs are added: ä, ö, ü, ß. The keyboard layout changes to 'QWERTZ'. The characteristic feature of such keyboard is 'ß' sign located on the right side of 'zero' sign.

Caution! Free Link printout option enables use of signs available exclusively using keyboard. Key combination (pressing letter and 'Shift' button at the same time) allows writing capital letters and special characters. Polish and German were completed with basic special characters written using key combination of a letter and right 'Alt' button. Other special characters are not operated in Free Link printout option.

An exemplary measurement printout is described in the PRINTOUTS section.

Additionally you can send a controlling code (of a hexadecimal form) to a printer either at the beginning of the printout - <PREFIX> parameter, or at the end of it - <SUFFIX> parameter. Sending these codes allows to control globally both, information and actions carried out at the beginning and/or at the end of each printout sent from a balance to a printer.

This function is most frequently used to send an information about the code page of a printout sent by a balance, at the beginning, and to send a command enabling the crop of a paper in EPSON printers (if the printer is equipped with an autocutter blade), at the end. <PREFIX> and <SUFFIX> parameters settings are available for all the printouts sent from balance, e.g. calibration reports, and for the header, footer and GLP printouts.

CAUTION!

It must be remembered that inserting paper crop command to <SUFFIX> parameter (control code) results in sending the code after each printout. If you wish for one whole printout to consist of: HEADER, GLP PRINTOUT and FOOTER and to be cropped underneath the FOOTER, then the paper crop command should be inserted only for FOOTER settings as a non-standard printout with <{151}> variable (paper crop for EPSON printer). In such a case <SUFFIX> command must remain empty.

To ensure correct cooperation of the balance with the printer (correct printout of diacritical signs of a given language), respective baud rate obligatory for a given printer must be chosen (see the printer settings). Additionally code page of a sent printout must be accordant with a code page of a printer.

Accordance of a code page may be obtained in two ways:

- setting the right code page in the settings of a printer (see a user manual of the printer) – it must be accordant with the printout code page of a balance:

| <i>Code page</i> | <i>Language</i> |
|------------------|---|
| 1250 | POLISH, CZECH, HUNGARIAN |
| 1251 | RUSSIAN |
| 1252 | ENGLISH, GERMAN, SPANISH, FRENCH, ITALIAN |
| 1254 | TURKISH |
| 1256 | ARABIAN |

- sending the control code from the balance, which automatically sets the right code page of the printer (code page accordant with the one of a balance) prior to printout of

data taken from the balance (this possibility is available only for printers with such option – see a user manual of the printer).

CAUTION!

CODES MUST BE ENTERED IN A HEXADECIMAL FORM!

Example balance settings for correct cooperation (printout of Polish signs) with EPSON thermal printer connected to RS232 port:

1. with impact printer, EPSON TM-U220D

Communication parameters for port to which the printer is connected:

- baud rate - 9600 bit/s
- parity - none

Printer parameters for PERIPHERALS group:

- port - COM 1 or COM 2 (the one to which the printer is connected)
- code page - **852**

2. with thermal printer, EPSON TM-T20

Communication parameters for port to which the printer is connected:

- baud rate - 38400 bit/s
- parity - none

Printer parameters for PERIPHERALS group:

- port - COM 1 or COM 2 (the one to which the printer is connected)
- code page - **1250**
- prefix - **1B742D**

or

- port - COM 1 or COM 2 (the one to which the printer is connected)
- code page - **852**
- prefix - **1B7412**

If in the place of the last digit there are any unexpected signs on the printout (for verified balances), than <CONTROL CODES> parameter should incorporate, apart from code page, code of the UK signs chart: **1B5203**. In such a case the <CONTROL CODES> parameter setting should be as follows: *prefix* - **1B74121B5203**.

Control codes for exemplary code pages and functions of the printer:

| <i>Control code</i> | <i>Page or other command</i> |
|---------------------|------------------------------|
| 1B7412 | Code page 852 |
| 1B742D | Code page 1250 |
| 1B742E | Code page 1251 |
| 1B7410 | Code page 1252 |
| 1B7430 | Code page 1254 |
| 1B7432 | Code page 1256 |
| 1B7433 | Code page 1257 |
| 1B5203 | UK signs chart |
| 1B5202 | DE signs chart |
| 1D564108 | Paper crop |
| 0C | Form feed (for PCL printers) |

21.3. USB Flash Drive

The balance software enables record of measurement data on an external flash drive.

Procedure:

1. Plug a USB flash drive into USB 1 port, type A.
2. Set <PENDRIVE> option for <PERIPHERALS/PRINTER/PORT>.
3. Set file format: *.txt or *.csv.
4. Return to weighing procedure.
5.  key, when pressed, provides record of measurement data (specified for GLP PRINTOUT), wherein the data is saved in a form of a text file, created automatically by balance software; the file name is: *printout.txt*.
6. Remove the USB flash drive from a balance USB port after about 10s counting from the last measurement record, only after this time the data is saved. Next plug the USB flash drive to a computer and read the saved text file using Notepad or Excel.

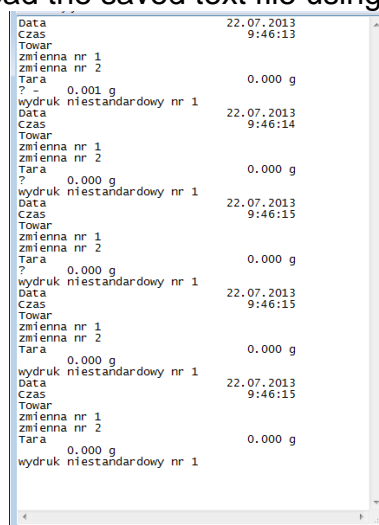
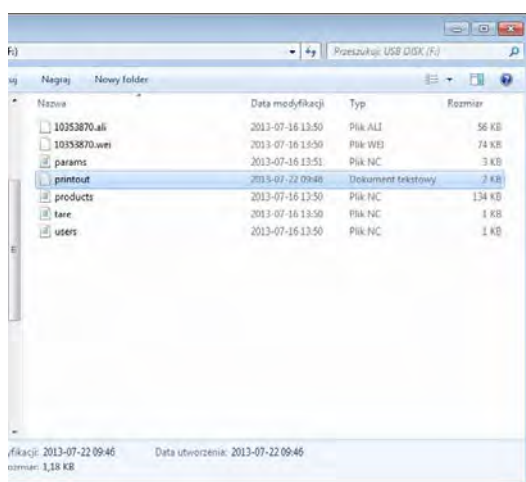

The data can be printed using any printer connected to a computer.

New data can be recorded to an existing file therefore you can continue recording measurement data using the file once created.

CAUTION! USB flash drive shall comprise <FAT file system>.

21.4. Barcode Reader

The balance can cooperate with a barcode reader.

The barcode is used for searching products database in order to find a respective product.

To set parameters for coupling the barcode reader go to <Parameters/Peripherals/Barcode reader> submenu.

You can set:

- Communication port, to which the barcode reader is to be coupled,
- Selected port parameters.

CAUTION! Go to <Communication> submenu to set baud rate accordant with barcode reader (by default it is 9600 b/s), this parameter can be set using barcode reader settings as well.

Procedure:

1. Press  button,
2. Enter <PERIPHERALS> submenu,
3. Enter <BARCODE READER> submenu,

4. Set balance parameters for cooperation with barcode reader:
5. <PORT> - selection of the port, to which the barcode reader is to be connected:
Accessible options: NONE, COM 1

21.5. Ambient Conditions Module

THB 3/5 module can be connected to the balance via COM1 port. In order to provide correct cooperation enter connected module address and baud rate for the port (port settings) to which the ambient conditions module is connected (the address and baud rate data is to be found on an ambient conditions data plate).

Exemplary settings for connected ambient conditions module:

Baud rate – 115200 bit/s

Address - 15

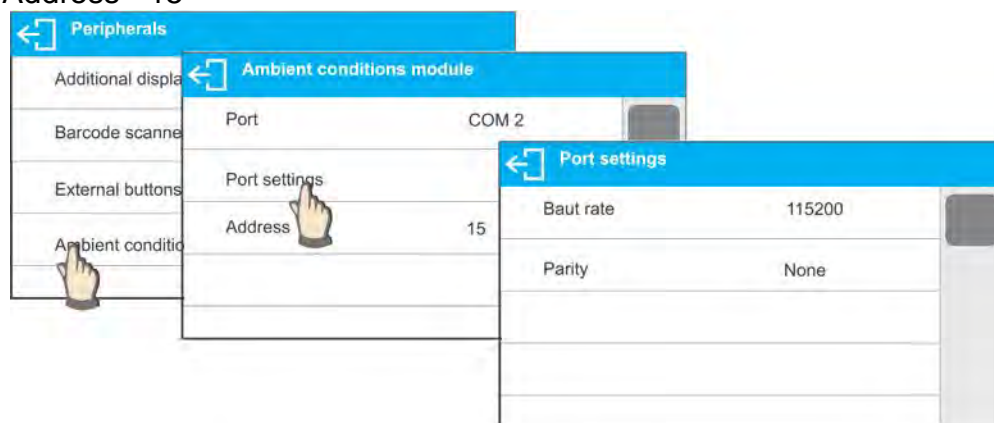

22. AMBIENT CONDITIONS

Parameters group designed to enable you to turn on readout of ambient conditions recorded by THB 3/5 ambient conditions module, and to specify tolerance temperature and humidity values and a change rate for the values per hour. Entered values are referred to indicted values. Next on the basis of values comparison respective pictograms are displayed informing you whether the sensor-read values are comprised within permissible limits or not. Particular sensors settings:

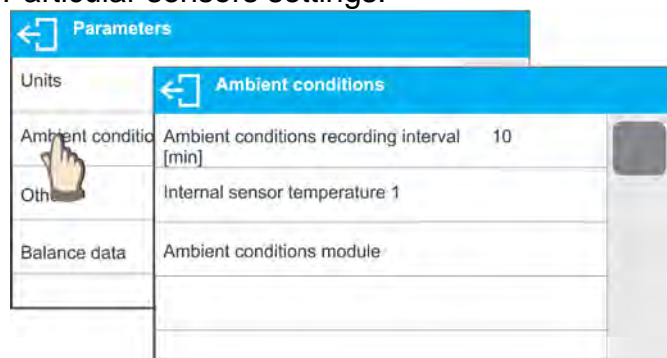

- Ambient conditions recording interval [min]: parameter enabling you to specify record frequency of sensor-registered data, and to determine how often the displayed pictograms (providing information on ambient conditions state) are to be refreshed,
- Internal sensor 1: enter this parameter to specify tolerance temperature values and balance temperature change rate.

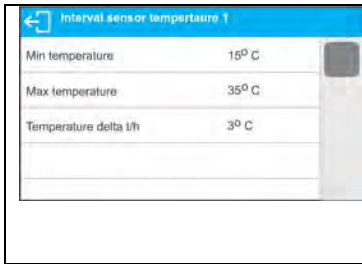

Min temperature – min balance temperature, for lower temperature values the thermometer pictogram is red
Max temperature – max balance temperature, for higher temperature values the thermometer pictogram is red
Temperature $\Delta t/h$ – maximum balance temperature change rate, for higher change rate values the balance displays blinking red thermometer pictogram

In order to enable/disable parameter visibility go to service menu.

- Ambient conditions module: parameters group which has been designed to enable you to turn on readout of data recorded by a balance-connected ambient conditions module, and to specify tolerance values for this module.

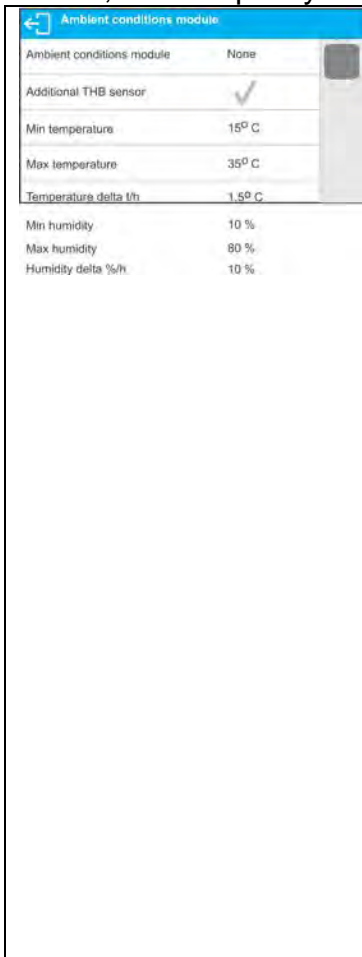





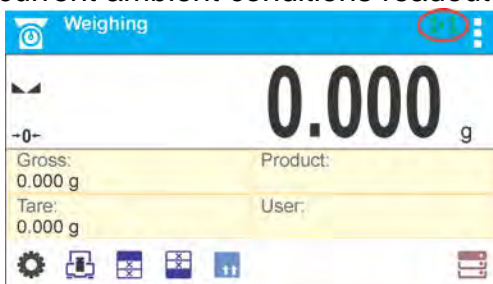

Ambient conditions module – parameter specifying module's working mode. Available options: **None** – readout of ambient condition module indications turned off; **Record** - readout and record of indications into database turned on, **Record and alert** – readout and record of indications into database turned on, option of display of warnings informing on ambient conditions change turned on, the warnings are displayed in accordance with the following tolerance values settings.
Additional temperature sensor – turning on readout of indication of the additional temperature sensor connected to the ambient conditions module.
Min temperature – min balance temperature, for lower temperature values the thermometer pictogram is red
Max temperature – max balance temperature, for higher temperature values the thermometer pictogram is red
Temperature $\Delta t/h$ – maximum balance temperature change rate, for higher change rate values the balance displays blinking red thermometer pictogram
Min humidity – min humidity value, for lower humidity values the thermometer pictogram is red
Max humidity – max humidity value, for higher humidity values the thermometer pictogram is red
Humidity $\Delta \%/h$ – maximum humidity change rate, for higher change rate values the balance displays blinking red thermometer pictogram

With all the parameters set, the home screen displays respective pictograms informing on current ambient conditions readouts and their change.



Pictograms for ambient conditions state:

| No. | Pictogram | Overview |
|-----|---|--|
| 1 |  | Indicated temperature is within specified permissible limits |
| 2 |  | Indicated temperature is out of specified permissible limits |
| 3 |  | Indicated humidity is within specified permissible limits |
| 4 |  | Indicated humidity is out of specified permissible limits |
| 5 |  | Too quick temperature change rate (blinking pictogram) |
| 6 |  | Too quick humidity change rate (blinking pictogram) |

23. COMMUNICATION PROTOCOL

General information

- A. A character based communication protocol balance-terminal is designed for establishing communication between a RADWAG balance and a peripheral device via RS-232C serial interface.
- B. It consists of commands sent from a peripheral device to the balance and responses from the balance.
- C. Responses are sent from the balance on each receipt of a command as a reaction to a specific command.
- D. Commands, forming the communication protocol, enable both, obtaining data on balance status and influencing balance operation, e.g.: acquiring measurement results from the balance, zeroing, etc.

23.1. List of Commands

| Command | Command overview |
|------------|---|
| Z | Zero balance |
| T | Tare balance |
| OT | Give tare value |
| UT | Set tare |
| S | Send stable measurement result in basic measuring unit |
| SI | Immediately send measurement result in basic measuring unit |
| SU | Send stable measurement result in current measuring unit |
| SUI | Immediately send measurement result in current measuring unit |
| C1 | Switch on continuous transmission in basic measuring unit |
| C0 | Switch off continuous transmission in basic measuring unit |
| CU1 | Switch on continuous transmission in current measuring unit |
| CU0 | Switch off continuous transmission in current measuring unit |
| DH | Set min checkweighing threshold |
| UH | Set max checkweighing threshold |
| ODH | Give value of min checkweighing threshold |
| OUH | Give value of max checkweighing threshold |
| SM | Set mass value of a single item |
| TV | Set target mass value |
| RM | Set reference mass value |
| NB | Give balance serial number |
| SS | Value release |

| | |
|---------------|--|
| IC | Internal adjustment performance |
| IC1 | Disable automatic internal adjustment of the balance |
| IC0 | Enable automatic internal adjustment of the balance |
| K1 | Lock balance keypad |
| K0 | Unlock balance keypad |
| OMI | Give available working modes |
| OMS | Set working mode |
| OMG | Give current working mode |
| UI | Give accessible units |
| US | Set unit |
| UG | Give current unit |
| BP | Activate sound signal |
| PC | Send all implemented commands |
| BN | Give balance type |
| FS | Give Max capacity |
| RV | Give program version |
| A | Set autozero function |
| EV | Set ambient conditions state |
| FIS | Set filter |
| ARS | Set value release |
| LDS | Set last digit |
| LOGIN | Operator Logging |
| LOGOUT | Operator Logout |
| NT | Cooperation with PUE 7.1, PUE 10 terminal |

CAUTION! Each command must end with CR LF characters;

23.2. Response Format

On receipt of a command, the terminal sends a response in one of the following formats:

| | |
|-------------|--|
| XX_A CR LF | command understood and in progress |
| XX_D CR LF | command carried out (appears only after the command XX_A) |
| XX_I CR LF | command understood but not accessible at this moment |
| XX_^ CR LF | command understood but max threshold is exceeded |
| XX_v CR LF | command understood but min threshold is exceeded |
| XX_OK CR LF | command carried out |
| ES CR LF | command not recognised |
| XX_E CR LF | time limit exceeded while waiting for a stable measurement result (time limit is balance characteristic parameter) |

XX - stands for a name of a sent command

_ - stands for spaces

COMMANDS OVERVIEW

Zero balance

Format: **Z CR LF**

Response options:

- Z_A CR LF - command understood and in progress
- Z_D CR LF - command carried out
- Z_A CR LF - command understood and in progress
- Z_^ CR LF - command understood but zeroing range is exceeded
- Z_A CR LF - command understood and in progress
- Z_E CR LF - time limit exceeded while waiting for stable measurement result
- Z_I CR LF - command understood but not accessible at this moment

Tare balance

Format: **T CR LF**

Response options:

- T_A CR LF - command understood and in progress
- T_D CR LF - command carried out
- T_A CR LF - command understood and in progress
- T_v CR LF - command understood but taring range exceeded
- T_A CR LF - command understood and in progress
- T_E CR LF - time limit exceeded while waiting for stable measurement result
- T_I CR LF - command understood but not accessible at this moment

Give tare value

Format: **OT CR LF**

Response: **OT_TARE CR LF** - command carried out

Response format:

| | | | | | | | | | | |
|---|---|-------|------|-------|------|----|----|-------|----|----|
| 1 | 2 | 3 | 4-12 | 13 | 14 | 15 | 16 | 17 | 18 | 19 |
| O | T | space | tare | space | unit | | | space | CR | LF |

Tare - 9 characters with right justification

Unit - 3 characters with left justification

CAUTION!

Tare value is always given in calibration unit.

Set tare

Format: **UT_TARE CR LF**, where **TARE** – tare value

Response options:

- UT_OK CR LF - command carried out
- UT_I CR LF - command understood but not accessible at this moment
- ES CR LF - command not recognised (tare format incorrect)

CAUTION!

Use dot in tare format as decimal point.

Send stable measurement result in a basic measuring unit

Format: **S CR LF**

Response options:

- S_A CR LF - command understood and in progress
- S_E CR LF - time limit exceeded while waiting for stable measurement result
- S_I CR LF - command understood but not accessible at this moment
- MASS FRAME - response: mass value in a basic measuring unit

Response format:

| | | | | | | | | | | | |
|---|-------|------------------|-------|-----------|------|-------|------|----|----|----|----|
| 1 | 2-3 | 4 | 5 | 6 | 7-15 | 16 | 17 | 18 | 19 | 20 | 21 |
| S | space | stability marker | space | character | mass | space | unit | | | CR | LF |

An example:

S CR LF - command send form a computer
 S _ A CR LF - command understood and in progress
 S _ _ _ _ - _ _ _ _ _ 8 . 5 _ g _ _ CR LF - command carried out, response: mass value in a basic measuring unit.

where: _ - space

Immediately send measurement result in a basic measuring unit

Format: **SI CR LF**

Response options:

SI_I CR LF - command understood but not accessible at this moment
 MASS FRAME - immediate response: mass value in a basic measuring unit

Response format:

| | | | | | | | | | | | | |
|---|---|-------|------------------|-------|-----------|------|-------|------|----|----|----|----|
| 1 | 2 | 3 | 4 | 5 | 6 | 7-15 | 16 | 17 | 18 | 19 | 20 | 21 |
| S | I | space | stability marker | space | character | mass | space | unit | | | CR | LF |

An example:

S I CR LF - command sent from a computer
 S I _ ? _ _ _ _ _ 1 8 . 5 _ k g _ CR LF - command carried out, immediate response: mass value in a basic measuring unit

where: _ - space

Send stable measurement result in a current measuring unit

Format: **SU CR LF**

Response options:

SU_A CR LF - command understood and in progress
 SU_E CR LF - time limit exceeded while waiting for a stable measurement result
 SU_I CR LF - command understood but not accessible at this moment
 MASS FRAME - response: mass value in a current measuring unit

Response format:

| | | | | | | | | | | | | |
|---|---|-------|------------------|-------|-----------|------|-------|------|----|----|----|----|
| 1 | 2 | 3 | 4 | 5 | 6 | 7-15 | 16 | 17 | 18 | 19 | 20 | 21 |
| S | U | space | stability marker | space | character | mass | space | unit | | | CR | LF |

An example:

S U CR LF - command send form a computer
 S U _ A CR LF - command understood and in progress
 S U _ _ _ - _ _ 1 7 2 . 1 3 5 _ N _ _ CR LF - command carried out, response: mass value in a current measuring unit

where: _ - space

Immediately send measurement result in a current measuring unit

Format: **SUI CR LF**

Response options:

SUI_I CR LF - command understood but not accessible at this moment
 MASS FRAME - immediate response: mass value in a current measuring unit

Response format:

| | | | | | | | | | | | | |
|---|---|---|------------------|-------|-----------|------|-------|------|----|----|----|----|
| 1 | 2 | 3 | 4 | 5 | 6 | 7-15 | 16 | 17 | 18 | 19 | 20 | 21 |
| S | U | I | stability marker | space | character | mass | space | unit | | | CR | LF |

An example:

S U I CR LF - command sent from a computer
 S U I ? _ - _ _ _ 5 8 . 2 3 7 _ k g _ CR LF - command carried out, immediate response: mass value in a current measuring unit

where: _ - space

Switch on continuous transmission in a basic measuring unit

Format: **C1 CR LF**

Response options:

C1_I CR LF - command understood but not accessible at this moment

C1_A CR LF - command understood and in progress

MASS FRAME - response: mass value in a basic measuring unit

Response format:

| | | | | | | | | | | | | |
|---|---|-------|------------------|-------|-----------|------|-------|------|----|----|----|----|
| 1 | 2 | 3 | 4 | 5 | 6 | 7-15 | 16 | 17 | 18 | 19 | 20 | 21 |
| S | I | space | stability marker | space | character | mass | space | unit | | | CR | LF |

Switch off continuous transmission in a basic measuring unit

Format: **C0 CR LF**

Response options:

C0_I CR LF - command understood but not accessible at this moment

C0_A CR LF - command understood and carried out

Switch on continuous transmission in a current measuring unit

Format: **CU1 CR LF**

Response options:

CU1_I CR LF - command understood but not accessible at this moment

CU1_A CR LF - command understood and in progress

MASS FRAME - response: mass value in a current measuring unit

Response format:

| | | | | | | | | | | | | |
|---|---|---|------------------|-------|-----------|------|-------|------|----|----|----|----|
| 1 | 2 | 3 | 4 | 5 | 6 | 7-15 | 16 | 17 | 18 | 19 | 20 | 21 |
| S | U | I | stability marker | space | character | mass | space | unit | | | CR | LF |

Switch off continuous transmission in a current measuring unit

Format: **CU0 CR LF**

Response options:

CU0_I CR LF - command understood but not accessible at this moment

CU0_A CR LF - command understood and carried out

Set min checkweighing threshold

Format: **DH_XXXXX CR LF**, where: _ - space, **XXXXX** – mass format

Response options:

DH_OK CR LF - command carried out

ES CR LF - command not recognised (mass format incorrect)

Set max checkweighing threshold

Format: **UH_XXXXX CR LF**, where: _ - space, **XXXXX** - mass format

Response options:

UH_OK CR LF - command carried out

ES CR LF - command not recognised (mass format incorrect)

Give value of min checkweighing threshold

Format: **ODH CR LF**

Response: **DH_MASA CR LF** - command carried out

Response format:

| | | | | | | | | | | |
|---|---|-------|------|-------|------|----|----|-------|----|----|
| 1 | 2 | 3 | 4-12 | 13 | 14 | 15 | 16 | 17 | 18 | 19 |
| D | H | space | mass | space | unit | | | space | CR | LF |

Mass - 9 characters with right justification

Unit - 3 characters with left justification

Give value of max checkweighing threshold

Format: **O U H CR LF**

Response: **U H_M A S A CR LF** - command carried out

Response format:

| | | | | | | | | | | |
|---|---|-------|------|-------|------|----|----|-------|----|----|
| 1 | 2 | 3 | 4-12 | 13 | 14 | 15 | 16 | 17 | 18 | 19 |
| U | H | space | mass | space | unit | | | space | CR | LF |

Mass - 9 characters with right justification

Unit - 3 characters with left justification

Set mass value of a single item (only for PARTS COUNTING)

Format: **S M_XXXXX CR LF**, where: _ - space, XXXXX – mass format

Response options:

SM_OK CR LF - command carried out

SM_I CR LF - command understood but not accessible at this moment (e.g. mode other than PARTS COUNTING)

ES CR LF - command not recognised (mass format incorrect)

Set target mass value (e.g. for DOSING)

Format: **T V_XXXXX CR LF**, where: _ - space, XXXXX - mass format

Response options:

TV_OK CR LF - command carried out

TV_I CR LF - command understood but not accessible at this moment (e.g. mode other than DOSING)

ES CR LF - command not recognised (mass format incorrect)

Set reference mass value (e.g. for PERCENT WEIGHING)

Format: **R M_XXXXX CR LF**, where: _ - space, XXXXX – mass format

Response options:

RM_OK CR LF - command carried out

RM_I CR LF - command understood but not accessible at this moment (e.g. mode other than PERCENT WEIGHING)

ES CR LF - command not recognised (mass format incorrect)

Value release

Format: **S S CR LF**

Response options:

SS_OK CR LF - command understood and in progress

Command's function is similar to function of PRINT button located on an overlay,

Internal adjustment

Format: **I C CR LF**

Response options:

IC_A CR LF - command understood and in progress

IC_D CR LF - calibration completed

IC_A CR LF - command understood and in progress

IC_E CR LF - time limit exceeded while waiting for a stable measurement result

IC_I CR LF - command understood but not accessible at this moment

Disable automatic internal adjustment of the balance

Format: **I C1 CR LF**

Response options:

IC1_I CR LF - command understood but not accessible at this moment

IC1_E CR LF - operation disabled, e.g. for verified balance

IC1_OK CR LF - command carried out

Operation is disabled for verified balances.

For non-verified balances the command inhibits internal adjustment until it is enabled via IC0 command or until the balance is turned off. The command does not modify settings specifying calibration start.

Enable automatic internal adjustment of the balance

Format: IC0 CR LF

Response options:

IC0_I CR LF - command understood but not accessible at this moment

IC0_OK CR LF - command carried out

Operation is disabled for verified balances.

Give balance serial number

Format: NB CR LF

Response options:

NB_A_"x" CR LF - command understood, response: serial number

NB_I CR LF - command understood but not accessible at this moment

x – serial number of the device (inserted in between inverted commas)

An example:

Command: NB CR LF – return serial number

Response: NB_A_"1234567" – serial number of the device – "1234567"

Lock balance keypad

Format: K1 CR LF

Response options:

K1_I CR LF - command understood but not accessible at this moment

K1_OK CR LF - command carried out

Command locks the balance keypad (proximity sensors, touch panel) until the moment of turning the balance off or until sending K0 command

Unlock balance keypad

Format: K0 CR LF

Response options:

K0_I CR LF - command understood but not accessible at this moment

K0_OK CR LF - command carried out

Give available working modes

Command overview: Command returns accessible working modes.

Format: OMI <CR><LF>

Response options:

OMI <CR><LF>

n_"Nazwa modu" <CR><LF>: – command carried out, response: accessible working

n_"Nazwa modu" <CR><LF> modes

OK <CR><LF>

OMI_I <CR><LF> – command understood but not accessible at this moment

Mode name – parameter, working mode name, inserted in between inverted commas. The name takes form given on a particular balance display, it is provided in a currently selected language.

n – parameter, decimal value determining working mode number.

n → 1 – Weighing

19 – Drying

CAUTION! Working modes numbering is identical for each kind of balance. The numbers are assigned to working modes names. Some balances give only the number as a response.

An example 1:

Command: OMI <CR><LF> – return accessible working modes

Response: OMI <CR><LF> – accessible working modes are given

2_ "Parts counting" <CR><LF> in return:
 mode number + name

19_ "Drying" <CR><LF>
 OK <CR><LF> – command carried out

Set working mode

Command overview: Command sets particular working mode.

Format: OMS_n <CR><LF>

Response options:

OMS_OK <CR><LF> – command carried out

OMS_E <CR><LF> – error in-course of command execution, no parameter or incorrect format

OMS_I <CR><LF> – command understood but not accessible at this moment

n – parameter, decimal value determining working mode number. To see detailed description go to OMI command

An example:

Command: OMS_19<CR><LF> – set drying mode

Response: OMS_OK<CR><LF> – Drying mode set

Give current working mode

Command overview: Command returns currently set working mode.

Format: OMG <CR><LF>

Response options:

OMG_n_OK <CR><LF> – command carried out, response: current working mode

OMG_I <CR><LF> – command understood but not accessible at this moment

n – parameter, decimal value determining working mode number. To see detailed description go to OMI command.

An example:

Command: OMG<CR><LF> – return current working mode

Response: OMG_13_OK<CR><LF> – balance operates in Statistics working mode

Give accessible units

Command overview: Command returns units available for a particular device and for a current working mode.

Format: UI <CR><LF>

Response options:

UI_"x₁,x₂, ... x_n"_OK<CR><LF> – command carried out, returns accessible units

UI_I <CR><LF> – command understood but not accessible at this moment

x – unit symbols, separated by means of comas

x → g, mg, ct, lb, oz, ozt, dwt, tlh, tls, tlt, tlc, mom, gr, ti, N, baht, tola, u1, u2

An example:

Command: UI <CR><LF> – return available units

Response: UI_"g, mg, ct"_OK<CR><LF> – response: available units

Set current unit

Command overview: Command sets current unit for a particular device.

Format: US_x <CR><LF>

Response options:

US_x_OK <CR><LF> – command carried out, response: current unit

US_E <CR><LF> – error in-course of command execution, no parameter or incorrect format

US_I <CR><LF> – command understood but not accessible at this moment

x – parameter, units symbols: g, mg, ct, lb, oz, ozt, dwt, tlh, tls, tlt, tlc, mom, gr, ti, N, baht, tola, msg, u1, u2, next

CAUTION! if x=next, the command swaps to another available unit on the list (it simulates „unit” button )

pressing).

An example:

Command: US_mg<CR><LF> – set „mg” unit
Response: US_mg_OK<CR><LF> – „mg” set as a current unit

Give current unit

Command overview: command returns current unit.

Format: UG <CR><LF>

Response options:

UG_x_OK<CR><LF> – command carried out, response: current unit
UG_I <CR><LF> – command understood but not accessible at this moment
x – parameter, unit symbol

An example:

Command: UG<CR><LF> – return current unit
Response: UG_ct_OK<CR><LF> – currently set unit is „ct”

Activate sound signal

Command overview: command activates BEEP sound signal for a specified amount of time

Format: BP_CZAS <CR><LF>

Response options:

BP_OK <CR><LF> – command carried out, BEEP sound signal activated
BP_E” <CR><LF> – no parameter or incorrect format
BP_I <CR><LF> – command understood but not accessible at this moment

TIME – parameter, decimal value specifying how long shall the sound last, parameter given in [ms]. Recommended range <50 - 5000>.

If value greater than the permissible high limit is given, than BEEP sound is operated for the maximum permissible amount of time.

An example:

Command: BP_350<CR><LF> – activate BEEP for 350 ms
Response: BP_OK<CR><LF> – BEEP activated

CAUTION!

BEEP sound activated via BP command is inhibited if in-course of its activation the sound is activated by means of other device: keypad, touch panel, proximity sensors.

Send all implemented commands

Format: **PC CR LF**

Command: PC CR LF - send all implemented commands
Response: PC_A_”Z,T,S,SI...” - command carried out, the terminal displays all implemented commands.

Give balance type

Format: BN <CR><LF>

Response options:

BN_A_”x” <CR><LF> - command understood, response: balance type
BN_I <CR><LF> - command understood but not accessible at this moment

x – series of types for a particular balance (in between inverted commas), with general balance type in front

An example:

Command: BN <CR><LF> – return balance type
Response: BN_A_”AS” – balance type: ”AS R”

Give max capacity

Format: FS <CR><LF>

Response options:

FS_A_”x” <CR><LF> - command understood, response: Max capacity
FS_I <CR><LF> - command understood but not accessible at this moment

x – Max value of reading units (in between inverted commas)

An example:

Command: FS <CR><LF> – return Max capacity
 Response: FS_A "220.0000" – Max capacity: "220 g"

Give program version

Format: RV <CR><LF>

Response options:

RV_A "x" <CR><LF> - command understood, response: program version
 RV_I <CR><LF> - command understood but not accessible at this moment

x – program version (in between inverted commas)

An example:

Command: RV <CR><LF> – return program version
 Response: RV_A " 1.1.1" – program version: "1.1.1"

Set AUTOZERO function

Format: A_n <CR><LF>

Response options:

A_OK <CR><LF> – command carried out
 A_E <CR><LF> – error in-course of command execution, no parameter or incorrect format

A_I <CR><LF> – command understood but not accessible at this moment

n – parameter, decimal value determining autozero settings

n → 0 – autozero off

1 – autozero on

CAUTION!

Command changes settings for a current working mode.

An example:

Command: A_1<CR><LF> – turn autozero function on
 Response: A_OK<CR><LF> – autozero function is on

AUTOZERO function operates until it is turned off by A 0 command.

Set ambient conditions state

Format: EV_n <CR><LF>

Response options:

EV_OK <CR><LF> – command carried out
 EV_E <CR><LF> – error in-course of command execution, no parameter or incorrect format

EV_I <CR><LF> – command understood but not accessible at this moment

n – parameter, decimal value determining ambient conditions state

n → 0 – unstable ambient conditions

1 – stable ambient conditions

CAUTION!

Command changes settings for a current working mode.

An example:

Command: EV_1<CR><LF> – set value 'stable' for ambient conditions option
 Response: EV_OK<CR><LF> – ambient conditions option set to value 'stable'
 <AMBIENT CONDITIONS> parameter is set to value <STABLE> until command EV 0 swaps it to value <UNSTABLE>.

Set filter

Format: FIS_n <CR><LF>

Response options:

FIS_OK <CR><LF> – command carried out
 FIS_E <CR><LF> – error in-course of command execution, no parameter or incorrect format

FIS_I <CR><LF> – command understood but not accessible at this moment

n – parameter, decimal value determining filter number

- n → 1 – very fast
- 2 – fast
- 3 – average
- 4 – slow
- 5 – very slow

CAUTION!

The numbering is assigned to a particular filter name and it is identical for all balance types. The command changes settings for a current working mode if, for a particular balance type, filter settings are assigned to the working mode.

An example:

Command: FIS_3<CR><LF> – set average filter
 Response: FIS_OK<CR><LF> – average filter set

Set Value release

Format: ARS_n <CR><LF>

Response options:

- ARS_OK <CR><LF> – command carried out
- ARS_E <CR><LF> – error in-course of command execution, no parameter or incorrect format
- ARS_I <CR><LF> – command understood but not accessible at this moment

n – parameter, decimal value determining value release options

- n → 1 – fast
- 2 – fast+reliable
- 3 – reliable

CAUTION!

The numbering is assigned to a particular value release option and it is identical for all balance types. The command changes settings for a current working mode if, for a particular balance type, value release settings are assigned to the working mode

An example:

Command: ARS_2<CR><LF> – set value release parameter to fast+reliable option
 Response: ARS_OK<CR><LF> – fast+reliable option set

Set last digit

Format: LDS_n <CR><LF>

Response options:

- LDS_OK <CR><LF> – command carried out
- LDS_E <CR><LF> – error in-course of command execution, no parameter or incorrect format
- LDS_I <CR><LF> – command understood but not accessible at this moment

n – parameter, decimal value determining last digit settings

- n → 1 – always
- 2 – never
- 3 – when stable

CAUTION!

The numbering is assigned to a particular last digit option and it is identical for all balance types. The command changes settings for a current working mode if, for a particular balance type, last digit settings are assigned to the working mode.

An example:

Command: LDS_1<CR><LF> – set last digit option to value 'always'
 Response: LDS_OK<CR><LF> – 'always' value set

User logging

Format: LOGIN_Nazwa,Hasło CR LF

where: _ - space (enter name and password in a form provided by the balance – lower-case letters and upper-case letters)

Response options:

- LOGIN OK CR LF – command understood, new operator logged in
- LOGIN ERROR CR LF – command understood, name or password error occurrence, logging operation cannot be carried out
- ES CR LF – command not understood (format error)

User logout

Format: LOGOUT CR LF

Response options:

- LOGOUT OK CR LF - command understood, operator logged out
- ES CR LF - command not understood (format error)

Cooperation with PUE 7.1, PUE 10 terminal

Format: NT CR LF

Response options:

- ES CR LF - command not understood (format error)
- MASS FRAME - response: mass value in a basic measuring unit

Response format:

| | | | | | | | | | | | | | | | | | | |
|---|---|-------|------------------|-------------|--------------|--------------|-------|------|-------|-----------|-------|-------|-------|-----------|-------|------------------------|----|----|
| 1 | 2 | 3 | 4 | 5 | 6 | 7 | 8 | 9-18 | 19 | 20-22 | 23 | 24-32 | 33 | 34-36 | 37 | 38 | 39 | 40 |
| Z | T | space | stability marker | zero marker | range marker | digit marker | space | mass | space | mass unit | space | tare | space | tare unit | space | Hidden digits quantity | CR | LF |

- NT - command
- Stability marker - [space] if stable, [?] if unstable
- Zero marker - [space] for any value but zero, [Z] for zero value
- Range marker - marker informing on range within which mass value is comprised: [space] I range balance, [2] II balance, [3] III balance
- Digit marker [zero] no digit, [1] one digit marker, [2] two digits marker, [3] three digits marker, [4] four digits marker, [5] five digits marker
- Mass 10 characters for net mass given in adjustment unit (with dot and a floating-point “-“ sign)
- Mass unit 3 characters - left justification
- Tare 9 characters with dot - right justification (when floating-point tare gets turned off automatically then zero value is sent)
- Tare unit 3 characters - left justification
- Hidden digits quantity Number specifying quantity of hidden digits: [space] when no digits are hidden, [1] when 1 digit is hidden

An example:

NT CR LF - command sent from a computer

NT _ ? _ _ 0 _ _ _ _ - 5 . 1 1 3 _ g _ _ _ _ _ 0 . 0 0 0 _ g _ _ _ 0 CR LF – command carried out, response: mass value and remaining data

Where: _ - space

- Stability marker [space] if stable [?] if unstable [^] if high limit is out of range [v] if low limit is out of range
- Character [space] for positive values [-] for negative values

Mass 9 characters with decimal point - right justification
 Unit 3 characters - left justification

23.3. Manual Printout / Automatic Printout

MA X2 moisture analyzer enables generating manual or automatic printouts.

- Manual printout: on stabilization of indication (measurement result) press  key.
- Automatic printout is generated automatically in accordance with the settings for automatic printout (see section 9 of this user manual).

The content of a printout depends on settings in menu <Standard printout> - <GLP printout> (see section 12.3 of this user manual).

Mass printout format:

| | | | | | | | | | |
|------------------|-------|-----------|-------|-------|------|----|----|----|----|
| 1 | 2 | 3 | 4 -12 | 13 | 14 | 15 | 16 | 17 | 18 |
| Stability marker | space | character | mass | space | unit | | | CR | LF |

Stability marker [space] if stable
 [?] if unstable
 [^] if high limit is out of range
 [v] if low limit is out of range

Character [space] for positive values
 [-] for negative values

Mass 9 characters with decimal point and right justification
 Unit 3 characters with left justification

An example:

___ 1 8 3 2 . 0 _ g _ _ CR LF - printout generated using balance upon pressing  key, the printout is generated with reference to settings for <GLP printout>:

| | | | |
|----------------------|-----------|-----------------------|-------------|
| Date | NO | Universal variable 3 | NO |
| Time | NO | Net | NO |
| User | NO | Tare | NO |
| Product | NO | Gross | NO |
| Customer | NO | Current result | YES |
| Packaging | NO | Adjustment report | NO |
| Universal variable 1 | NO | Non-standard printout | NONE |
| Universal variable 2 | NO | | |

24. PERIPHERALS

The balance can cooperate with the following peripheral devices:

- computer,
- EPSON labeller,
- PCL printer,
- an optional peripheral device operating in ASCII communication protocol.

25. ERROR MESSAGES



Max weighing threshold exceeded
Unload the weighing pan



Min weighing threshold exceeded
Install weighing pan



Zeroing out of range
Press tarring button or restart the balance



Display capacity out of range
Unload the weighing pan



Tarring out of range
Press zeroing button or restart the balance



Start mass out of range
Install weighing pan



Zeroing/tarring time out of range
Weighing indication unstable

26. USE OF MOISTURE ANALYZER

For measurement temperatures ranging from 161°C to 250°C the time of maintaining the temperature during the measurement is estimated proportionally, ~15 hours for 161°C – 10 min for 250°C.

For a drying process carried out in 250°C, Max temp is maintained for 10 min, next the program automatically lowers the temperature (drying is not interrupted) to 160°C.

Lowering temperature to 160°C takes ~10 min.

For QUICK drying mode Max drying temperature remanipulation is 30% but no more than Max temperature for a particular moisture analyzer.

27. MAINTENANCE ACTIVITIES

This section describes how to maintain the moisture analyzer in good condition, and how to replace its faulty components (filaments, fuses).

27.1. Cleaning Moisture Analyzer Components

In order to ensure required measuring accuracy, the moisture analyzer has to be used and stored clean.

While cleaning the moisture analyzer, obey precautions provided in this section.



REMEMBER, before initiating any maintenance or cleaning activities or when replacing a fuse or a filament, switch off the moisture analyzer and make sure the power cord is unplugged from the mains!

Open moisture analyzer's cover and take out all components of the drying chamber: disposable pan, drying pan handle, cross-shaped holder, drying pan shield, drying chamber base insert.

Clean the moisture analyzer using soft fabrics (diaper, chamois, etc.) and non-aggressive cleaning agents.

Do not use any abrasive agents or solvents to clean the moisture analyzer, as it may cause damage to the device and its components.

Upon cleaning let the subassemblies dry. Make sure no liquids or dirt get inside the drying chamber.

Install clean components following the diagram.

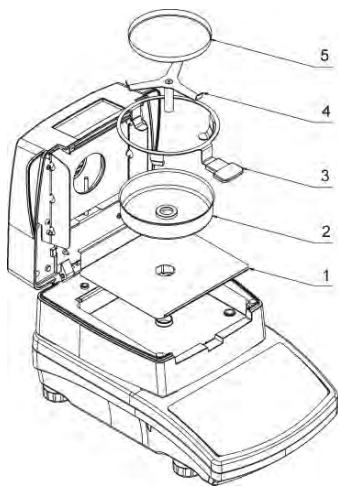

27.2. Cleaning Temperature Sensor

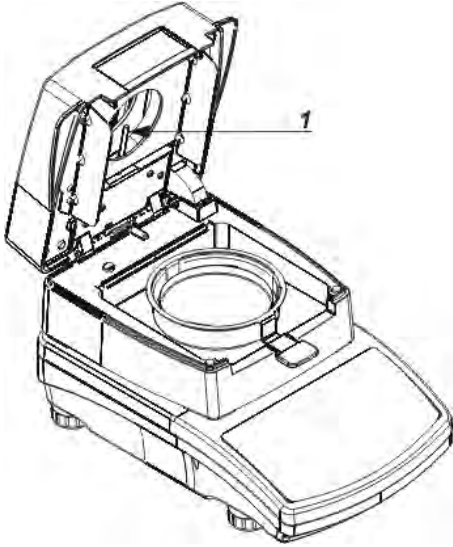

To ensure correct temperature measurement make sure that the temperature sensor is clean (1).

Take extra precautions while cleaning the device.

Clean the moisture analyzer using soft fabrics and mild cleaning agents.

Do not use any abrasive agents or solvents as it may cause damage to the sensor.

Neither IR emitter nor halogen shall be touched in the course of cleaning activities, this is to prevent risk of damage.

It is possible to clean emitter's shields if there is such a necessity, use soft fabrics exclusively and remember not to touch the emitters.

27.3. Troubleshooting

Problem: no reaction to pressing main switch on/off key (display remains dark).

Probable cause:

- no voltage in the mains,
- damaged power cord,
- damaged fuse of the moisture analyzer,
- moisture analyzer's defect.

Problem: too long pending time for drying process finish.

Probable cause:

- Incorrect finish mode selected. Carry out experimental tests to select a proper finish mode.

Problem: lack of measurements repeatability

Probable cause:

- non-uniform sample content; prepare the sample using larger amount of substance.
- the drying time is too short; change finish mode.
- drying temperature is too high, causing sample's oxidizing; lower drying temperature.
- tested sample boils; lower the drying temperature.
- the temperature sensor is contaminated or defected; clean the temperature sensor.
- the weighing table on which the moisture analyzer is located is unstable; move the device to a different workstation.
- the ambient area is incompatible with the requirements (vibrations, drafts, etc.); change the ambient conditions for compatible ones according to the guidelines of this user manual.

28. ADDITIONAL EQUIPMENT

| Type | Name |
|---------|-------------------------------|
| P0151 | Cable RS232 for EPSON printer |
| EPSON | Impact/thermal printer |
| CITIZEN | Labeller |
| | PCL Printer |
| SAL | Anti-vibration table |
| | PC keyboard – USB type |

29. INFORMATION ON MOISTURE ANALYZER

This menu provides you with information on moisture analyzer and its installed software. The parameters are strictly informative.

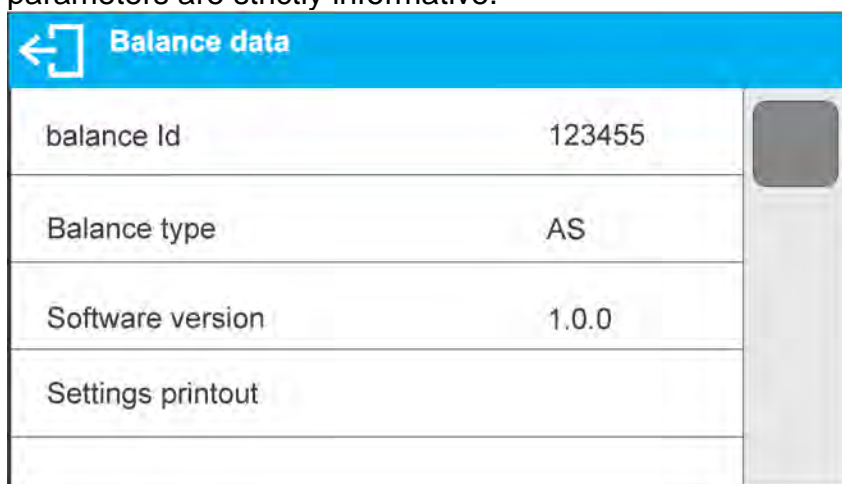

| Balance data | |
|-------------------|--------|
| balance Id | 123455 |
| Balance type | AS |
| Software version | 1.0.0 |
| Settings printout | |

Once the parameter <PRINT. SET> is chosen, the settings are sent to the printer (all parameters).

User manual no.:
IMMU-21-05-01-17-EN



RADWAG BALANCES AND SCALES
ADVANCED WEIGHING TECHNOLOGIES

